



INSTALLATION MANUAL

# M-SC3.5

- 3000 RPM -

Marine diesel generating set 230V / 50Hz

Digital Diesel Control



Art.nr. 40261141

WHISPER POWER BV  
Kelvinlaan 82  
9207 JB Drachten  
Netherlands  
Tel.: +31-512-571550  
Fax.: +31-512-571599  
[www.whisperpower.eu](http://www.whisperpower.eu)

V1. May 2010

## CONTENTS:

<b>1</b>	<b>INSTALLATION</b> .....	<b>3</b>
1.1	Location .....	3
1.2	Instructions for optimal sound and vibration insulation .....	<b>Fout! Bladwijzer niet gedefinieerd.</b>
1.2.1	Steel base plate .....	3
1.2.2	Further recommendations .....	3
1.3	Ventilation .....	4
1.4	Connections .....	5
1.4.1	Fuel supply .....	5
1.4.2	Cooling .....	7
1.4.3	Exhaust system .....	<b>Fout! Bladwijzer niet gedefinieerd.</b>
1.4.4	Control system .....	11
1.4.5	AC power system (230 Volt) .....	15
<b>2</b>	<b>INSTALLATION SPECIFICATIONS</b> .....	<b>17</b>
2.1	M-SC3.5 installation table .....	17
2.2	Commissioning table .....	17
2.3	Installation specifications M-SC3.5 .....	18
2.4	Specification of the accessories .....	18
2.5	Installation materials M-SC3.5 .....	19
<b>3</b>	<b>DIAGRAMS &amp; DRAWINGS</b> .....	<b>24</b>
3.1	DC wiring diagram .....	24
3.2	Wiring names and colours .....	27
3.3	AC wiring diagram 230V / 50Hz .....	28
3.4	Dimensions MasterView Easy Panel .....	29
3.5	Dimensions M-SC3.5 .....	29
<b>4</b>	<b>MASTERBUS</b> .....	<b>30</b>
4.1	What is MasterBus? .....	30
4.2	Event-based commands .....	30
4.3	How to set up a MasterBus network .....	31

# 1 INSTALLATION

This installation manual is valid for the following models:

Part number	Description
41200500	M-SC3.5 / 230V 3000rpm wet exhaust MasterBus controlled
41200506	M-SC3.5 / 230V 3000rpm wet exhaust MasterBus controlled - ungrounded

For other models see our website: [www.whisperpower.eu](http://www.whisperpower.eu).

To ensure reliability and durability of the equipment, it is very important that the installation is carried out with the utmost care and attention. To avoid problems, such as temperature problems, noise levels, vibration, etc. the instructions set out in this manual must be followed and all installation work must be carried out professionally.

## 1.1 LOCATION

Since Whisper generating sets have extremely compact dimensions, they can be installed in tight locations. Please consider that even almost maintenance-free machinery must still remain accessible.

When selecting the location area in which to mount the generating set, make sure there is sufficient room to carry out any maintenance work. The unit must be easily accessible on the service side and on the distribution side to have access to the raw water pump and oil strainer.

Please also note that in spite of the automatic oil pressure sensor it is still essential that the oil level is checked regularly.

## 1.2 INSTRUCTIONS FOR OPTIMAL SOUND AND VIBRATION INSULATION

Position the generating set as low as possible in the vessel. As the generating set is already secured to the base frame by means of flexible engine mountings, the frame can be mounted directly to the vessel's main structure.

### 1.2.1 Steel base plate

However to keep resonant vibrations at a minimum, it is recommended to mount the generating set on a solid steel base plate, approx. 30 mm weighing approx. 44 kg or 50% of the weight of the generating set. The engine draws its inlet combustion air through several holes in the capsule base. Therefore the capsule must be fitted with sufficient clearance between the capsule underside and the base plate. A steel base plate is available from Whisper Power as an optional accessory (ref. fig. 23, page 21).

### 1.2.2 Further recommendations

Whisper generating sets are standard equipped with a "GRP" (Glass Reinforced Plastic) sound cover. The canopy has been designed to give effective sound insulation. For optimum sound and vibration dampening, the following factors should be considered.

- 1 Avoid mounting the generating set in close proximity to thin walls or floors that may cause resonance.
- 2 Sound dampening is extremely poor if the generating set is mounted on a light weight flimsy surface such as plywood which will only amplify vibrations. If mounting on a thinner surface cannot be avoided, this should at least be reinforced with stiffening struts or ribbing. If possible, holes should be bored or cut through the surface to help reduce the resonance. Covering the surrounding walls and floors with a heavy coating plus foam will certainly improve the situation.

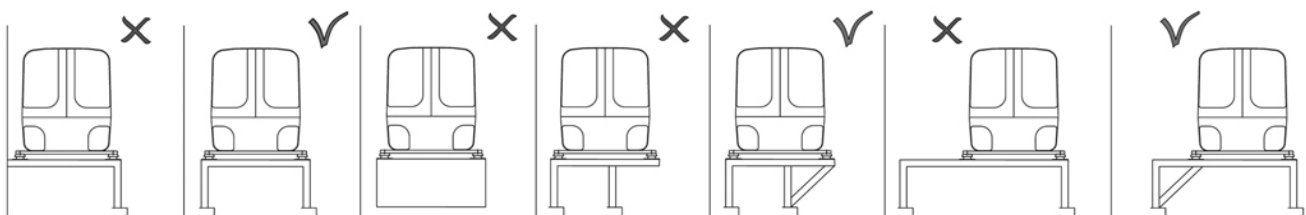

Figure 1: Mounting of the Whisper generating set. X = wrong, V = OK

- 3 Never connect the base of the generating set directly to bulkheads or tanks.

### 1.3 VENTILATION

The generating set normally draws air from the engine room. Engine rooms with natural ventilation must have vent openings of adequate size and location to enable the generating set to operate without overheating. To allow an ample supply of air within the temperature limits of the generating set an opening of at least 100 cm<sup>2</sup> is required. A "sealed" engine compartment must have a good extraction ventilator to maintain reasonable engine room temperatures. High temperature of intake air reduces engine performance and increases engine coolant temperatures. Air temperatures above 40°C reduce the engine power by 2% for each 5°C of rise. To minimise these effects the engine room temperature must not be more than 15°C above the outside ambient air temperature.

Apply a combination of ventilators, blowers and air intake ducting to meet the temperature limit. The air inlet ducts should run to the bottom of the engine room to clear fumes from the bilge and to circulate fresh air. Air outlets should be at the top of the engine room to remove the hottest air. An engine room blower should be used as an extraction ventilator to remove air from the engine room. In cases where it is impossible to meet the above mentioned temperature limit by using machine room ventilation, connections are to be made for an air inlet directly to the enclosure. With these connections the generating set can be directly connected to an air duct.

Air inlets should be louvered, where appropriate, to protect the engine room and to protect the generating set from water spray. As an extra precaution, the fitting of a cowl ventilator with a cover box located as high as possible, is recommended.

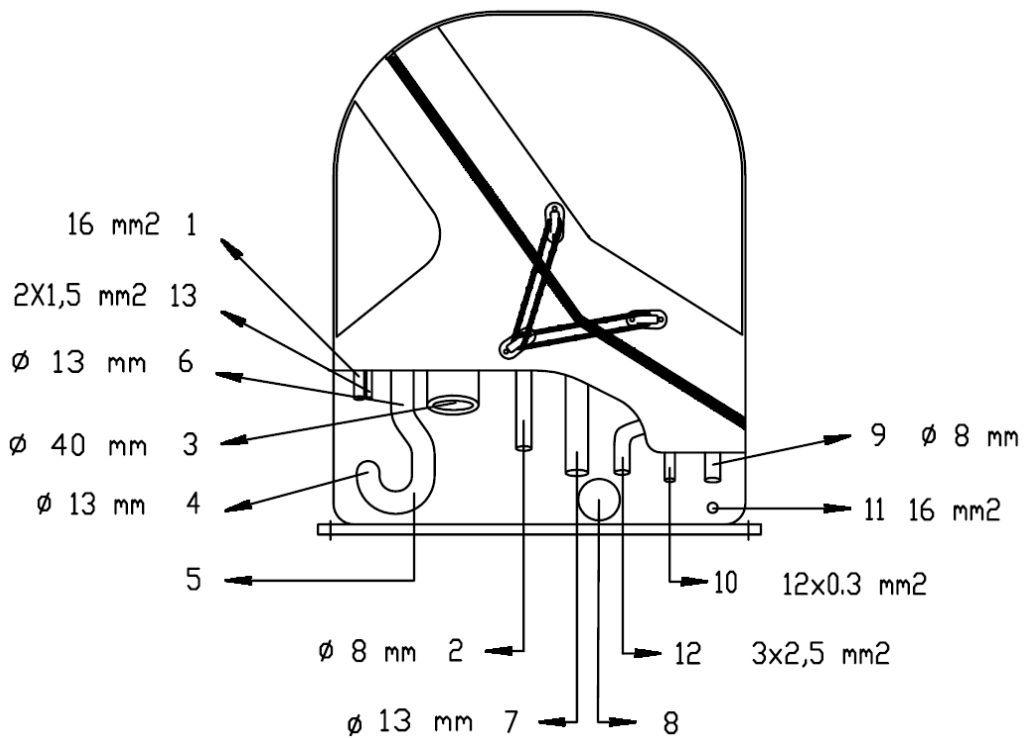

- |               |                    |                 |                         |
|---------------|--------------------|-----------------|-------------------------|
| 1 Battery POS | 5 By-pass air vent | 9 Fuel in       | 13 Cable fuel lift pump |
| 2 Fuel return | 6 Water return     | 10 Remote cable |                         |
| 3 Exhaust     | 7 Water in         | 11 Battery NEG  |                         |
| 4 Water out   | 8 Oil strainer     | 12 AC cable     |                         |

Figure 2

## 1.4 CONNECTIONS

The generating set comes supplied with all supply lines and output cable (i.e. electric cables, cooling water connections, exhaust, fuel lines etc.) already connected to the engine and generator. The supply lines are fed through the capsule's front base. The connections are marked as shown in figure 2.

All electrical connections, cable types and sizes must comply with the appropriate national regulations. Supplied cables are rated for ambient temperatures up to 70°C. If the cables are required to meet higher temperature requirements, they must be run through conduits.



### ATTENTION!

Before working (installation) on the system read the section safety instructions.

### 1.4.1 Fuel supply

#### 1 FUEL TANK

Fuel tanks should be made of appropriate material such as (stainless) steel or plastic. Steel tanks should not be galvanised or painted inside. Condensation can occur in metal tanks when temperature changes. Therefore, water accumulates at the bottom of the tank and provisions should be made for the drainage of this water.

The tank will need a filling connection, a return connection and an air ventilation connection which will require protection against water entry.

Some official regulations do not allow connection points at the base of the fuel tank; in this instance connections are to be made at the top of the tank with internal tubing down to a few cm above the bottom of the tank.

#### 2 FUEL LIFT PUMP

The generating set itself is equipped with a fuel lift pump; therefore the tank can be installed at a lower level than the generating set. The maximum suction height is 1 m. If the pump has to lift the fuel higher than one meter an external fuel lift pump must be installed. The control board is already prepared to connect an extra fuel pump.

#### 3 FUEL PIPES

When the tank is above the generating set we recommend ending the return line on the top of the tank (A).

When the return is on the top - in case of a leakage the return line cannot overflow because of siphoning. One will only need a fuel cock in the fuel supply line.

When the tank is below the generating set we recommend ending the return line on the bottom of the tank (A) below the inlet of the supply line to discharge under the lowest fuel level. This prevents air getting into the fuel line. Here also one needs a fuel cock only in the supply line Both supply and return fuel pipe lines should be appropriate material and 8 mm outer diameter tubing. The quality of

the tubing of fuel pipes could be submitted to local regulations depending on the application of the vessel.

The fuel pipes can be plumbed to the flexible hoses which are on the generating set and have a connection to fit to 8 mm pipe. This fuel lines fulfils CE standards and are according to ISO 7840 A2. It is important to avoid bends in the pipes, as they could trap air bubbles. The return pipe should never be connected to the suction pipe. Other consumers of diesel fuel, such as the propulsion engine and heaters, have to be connected to separate suction and return pipes.

#### 4 FUEL FILTERS

A fine fuel filter is installed which requires maintenance. Whisper Power advises to install an extra fuel filter/ water fuel separator near the fuel tank.

Before starting your generating set for the first time follow the fuel system bleeding procedure in the users manual.

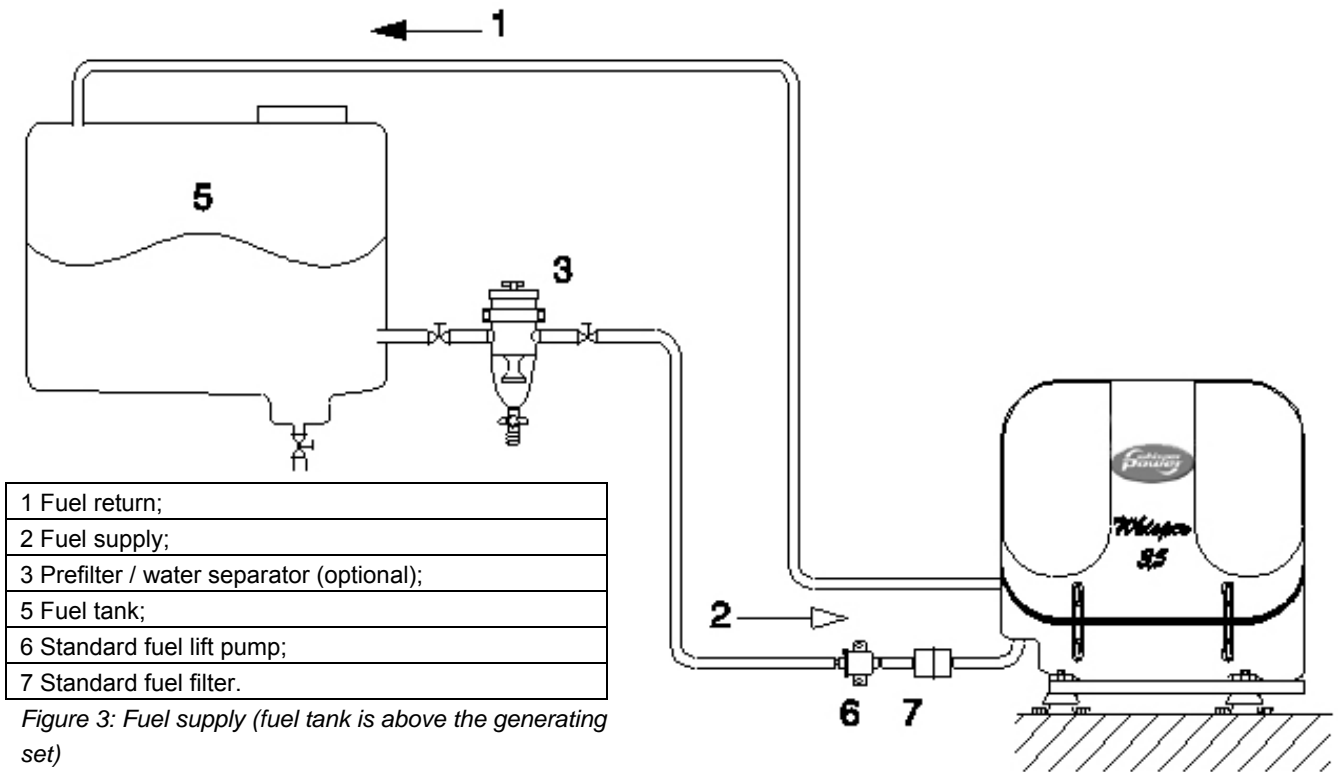

Figure 3: Fuel supply (fuel tank is above the generating set)

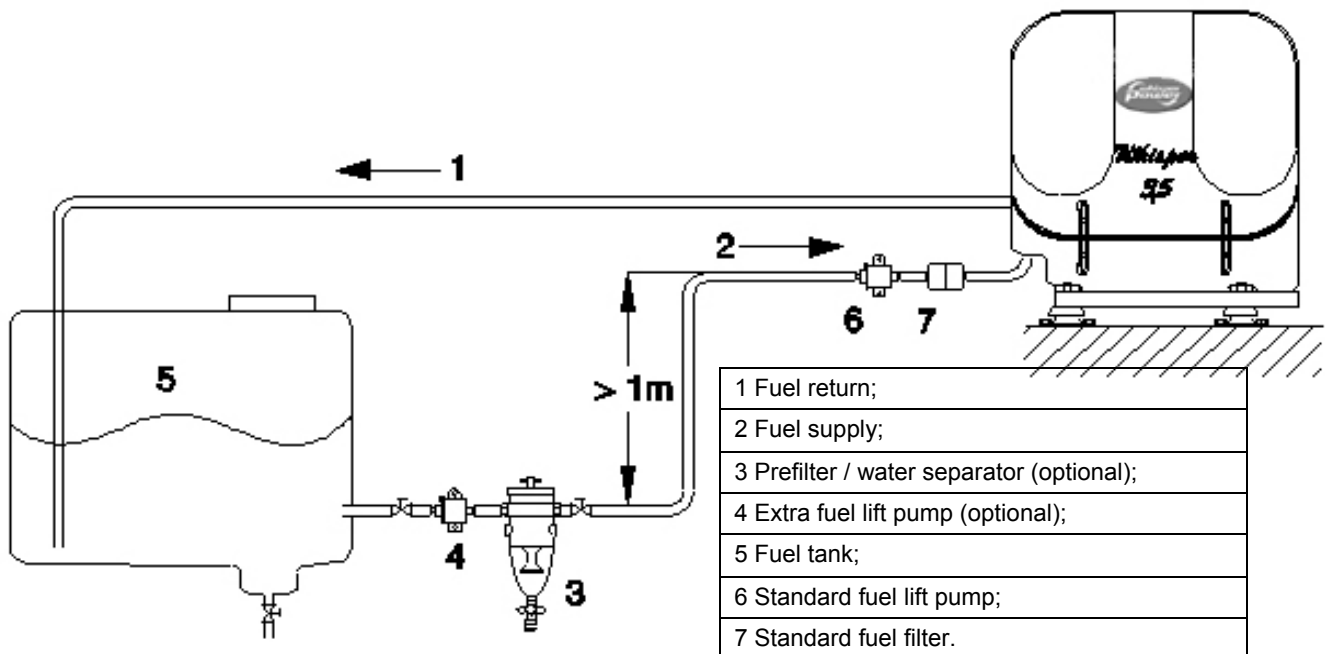

Figure 4: Fuel supply (fuel tank is above the generating set)

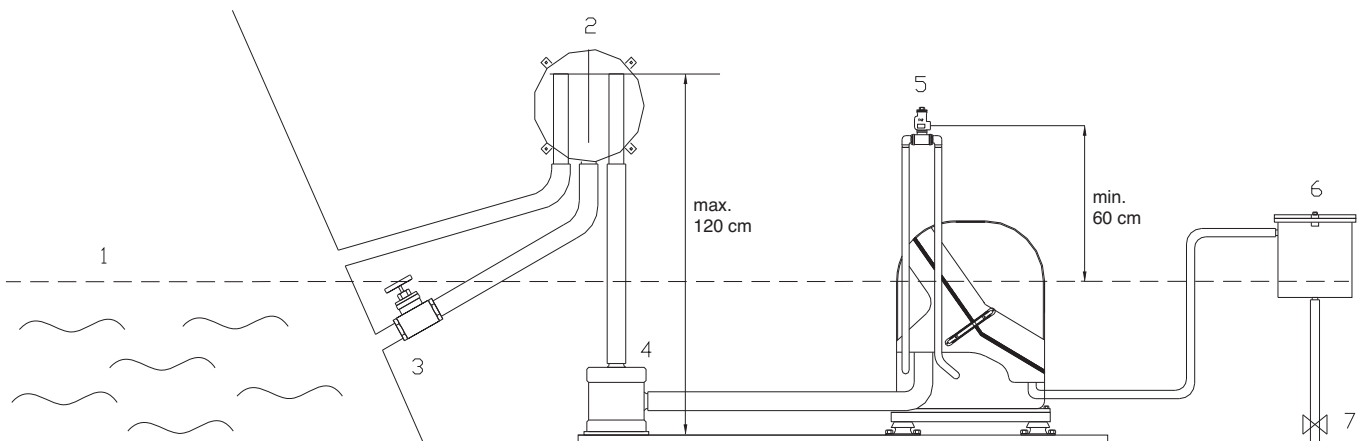

Figure 5: Internal cooling system

1 Water level  
2 Water/exhaust separator  
3 Seacock  
4 Waterlock

5 Air vent;  
6 Water strainer;  
7 Seacock.

### 1.4.2 Cooling

Intercooling is based on a raw water pump, heat exchanger and water-injected exhaust. The generating set should have its own sea water (coolant water) inlet and should not be connected to any other engine systems. A properly installed cooling system is critical to keep engine temperatures within an acceptable range. Ensure that the installation complies with the following installation instructions.

#### 1 RAW WATER SUPPLY

For raw water supply the following installation materials are required: -a skin fitting - a sea cock - a water strainer - hoses and clamps. In order to keep the suction resistance in the line at a minimum, the sea water intake system (i.e. sea cock, tru-hull fitting, inlet filter, etc.) must have an inner diameter of at least 12.5 mm diameter (1/2"). The suction hose should be kept as short as possible. Raw water plumbing should avoid bends as much as possible. Restriction of raw water flow, caused by kinked hoses, undersized pipes or connections, will reduce the engine cooling capability. This is the main cause for overheating of an engine. After running the generating set for the first time, check the coolant flow rate using a stopwatch and by holding a pail of a known volume under the wet-exhaust outlet. The flow rate should be 8 to 12 litres /min.

#### 2 INSTALLATION OF THROUGH HULL FITTING

It is good practice for yachts to use a hull inlet fitting with an integrated strainer (water scoop). For propulsion engines in motorboats the water scoop is often mounted against the sailing direction to induce more water intake for cooling.



**This should not be done in the case of a generating set! When sailing at higher speeds, water will be forced into the inlet and your generating set will overflow!**

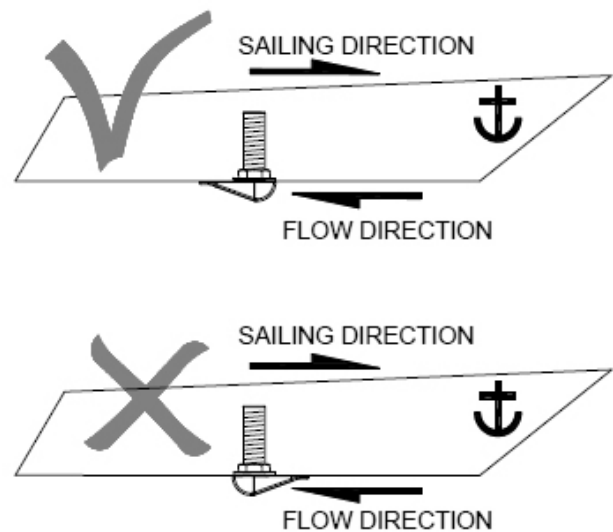

Figure 6: Installing water intake

On motorboats and on sailing boats the water scoop for a generating set should be fitted with the opening faced backwards to prevent water being forced in during sailing. Use a sealant when mounting the skin fitting.

#### 3 WATER STRAINER

Use an appropriate water strainer with connections of 12.5 mm (1/2"). Install the water strainer in a well accessible position, (refer to figure. 5, ref 6) 5 cm above the waterline.

#### 4 SIPHON BREAKER (AIR VENT)

When the point of water injection is below the waterline, then -when the engine is stopped -there is a risk that the cooling water may enter the engine as a result of siphoning. To avoid this happening, the generating set is designed to accommodate a siphon breaker (air vent). In the standard delivery the connections are bypassed. Hose of 12.5 mm (1/2") inner diameter should be used. If the generating set cannot be mounted such that the bottom of the generating set is placed above the waterline, an air vent must be installed. Extend the water hose of the bypass 600 mm above waterline and install an air vent. Ideally, the air vent should be mounted above the yacht keel center line (i.e. to minimize the influence of swaying on the water intake). The hose of the drain should go downwards. Water must flow out freely and air has to flow in freely as well (refer to figure 7).

Fast motorboats will lay deeper when sailing at large speed and can cause pressure on the waterinlet. This should be avoided to prevent flooding the engine. If the air vent is clogged the water hoses will not be vented when the generating set has stopped and water can be forced into the engine. This leads to immediate engine problems and eventually severe damage!



**DAMAGE CAUSED BY THE INGRESS OF WATER IN THE ENGINE IS NOT COVERED BY WARRANTEE**

On the valve is a little hose to drain a little water that could be spilled from the valve. This hose should go down and may not end under water, because it should ventilate air into the valve to break the siphoning (figure 7).

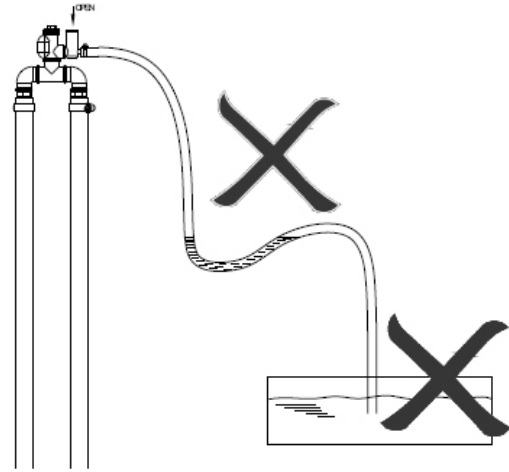

Figure 7: Wrong siphon breaker hose routing

Check the air vent at regular intervals. Open, clean and lubricate the valve as required (figure 8).

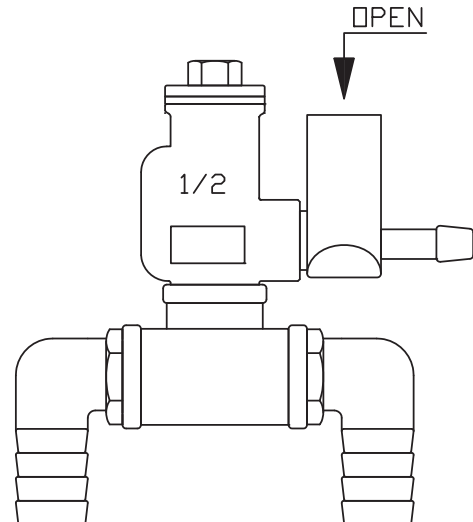

Figure 8



### 1.4.3 Exhaust system

Water is injected in the exhaust system of the generating set. In this way the cooling water that has passed the heat exchanger is mixed with the exhaust gases. Temperature and volume of the gases are thereby reduced considerably, so that a rubber exhaust hose can be used and the level of noise is reduced as well.

#### 1 STANDARD EXHAUST SYSTEM INSTALLATION

The generating set exhaust system must remain completely independent and separate from the exhaust system of any other engine on board. A water lock prevents the generating set from being flooded by cooling water and should be installed as close to the generating set as possible. The lock must be large enough to hold the entire water volume held in the hose from the top of the goose neck to the water lock. The water lock must be installed at the lowest point of the exhaust system (ref. to figure 9, ref. 1). The exhaust hose must have an inner diameter of 40 mm no less, no more-. The exhaust system must be installed so that the back pressure inside the exhaust does not exceed 0,8 psi 60 cm. waterpressure (refer to paragraph 5.4.3 of the users manual) and total length up to the outlet or water separator does not exceed 2,5 m. The exhaust hose descends from the capsule to the water lock. Then the hose rises maximum lift 120 cm via the "goose neck" to the through-hull exhaust outlet, situated minimum 50 mm above the water line (refer to figure 9, ref. 5). The "goose neck" must be vertical and

situated preferable along the ship's keel center line. It is recommended to install an extra muffler (see figure 9, ref. 2) close to the through-hull fitting.



**Because of the small gas flow of the small engine it is very important to keep strictly to the instructions above. Some mufflers and water locks cause too high back pressure. You are advised to use a Whisper Power installation kit or check the back pressure (refer to paragraph 5.4.3 of the users manual). Too high back pressure causes the system to fill up with water that affects the outlet valve and valve seat.**

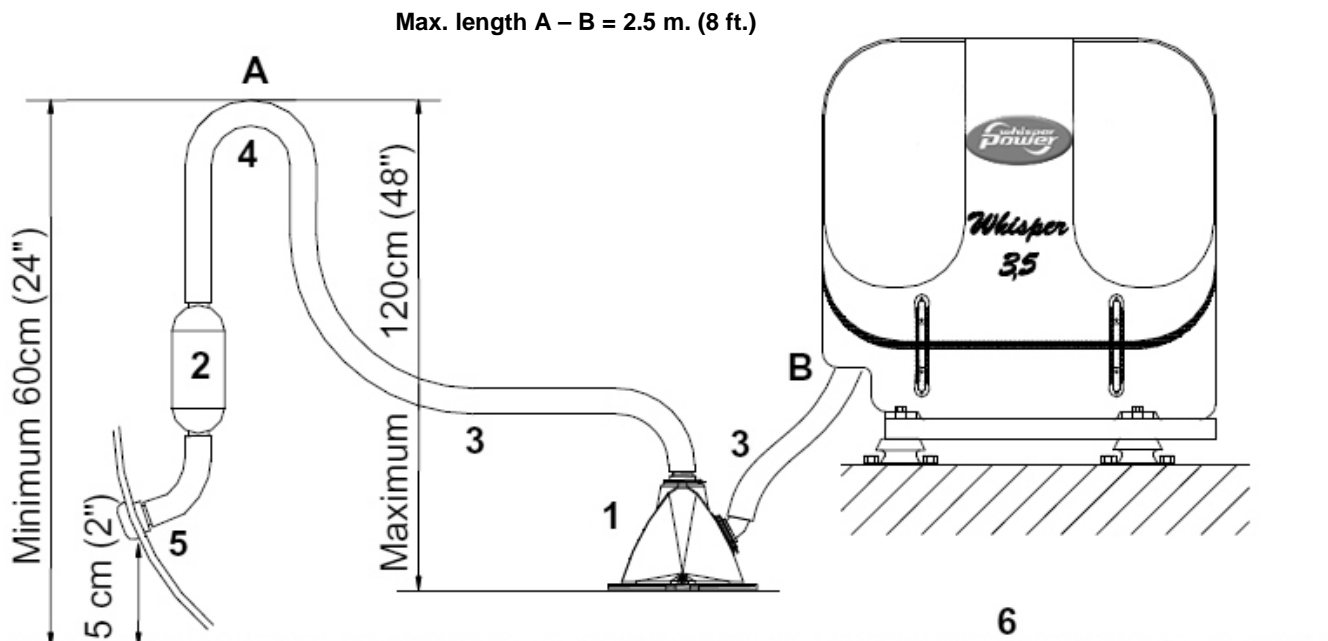

- |                           |  |
|---------------------------|--|
| 1 Exhaust water lock;     | 4 Goose neck;                          |
| 2 Exhaust outlet muffler; | 5 Through-hull exhaust outlet Ø 40 mm; |
| 3 Exhaust line Ø 40 mm;   | 6 Water level.                         |

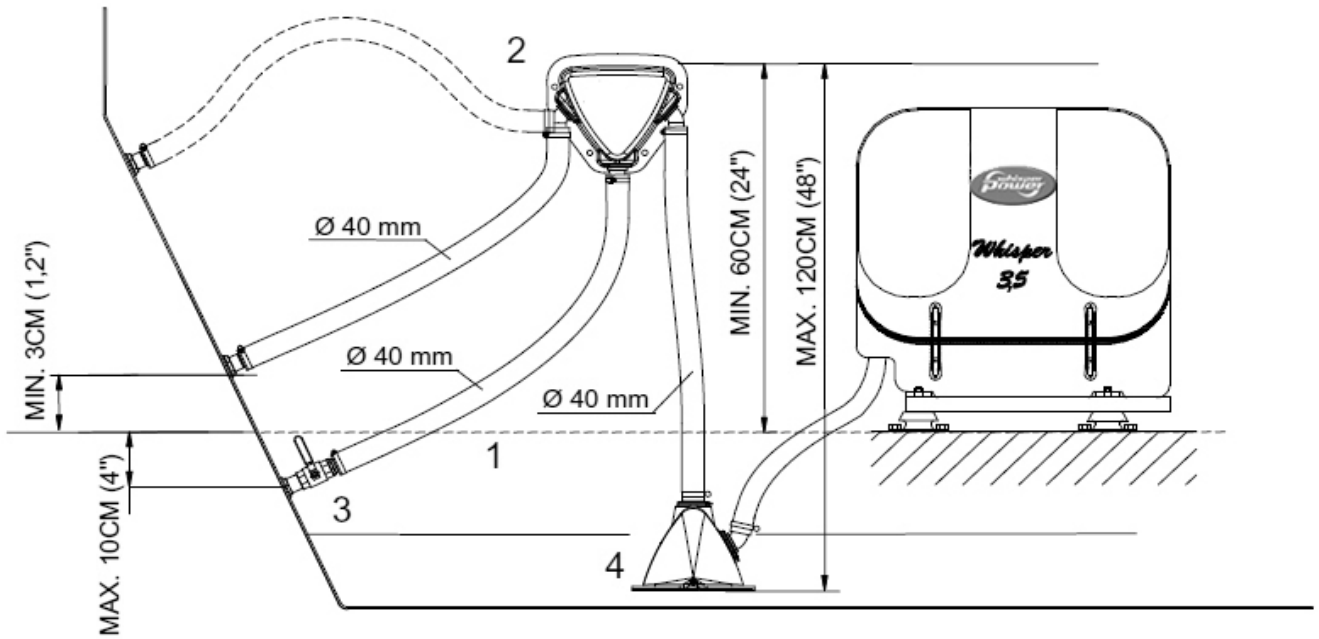

Figure 10: Super silent exhaust system

1 Water level;	3 Seacock;
2 Water/exhaust separator;	4 Waterlock;

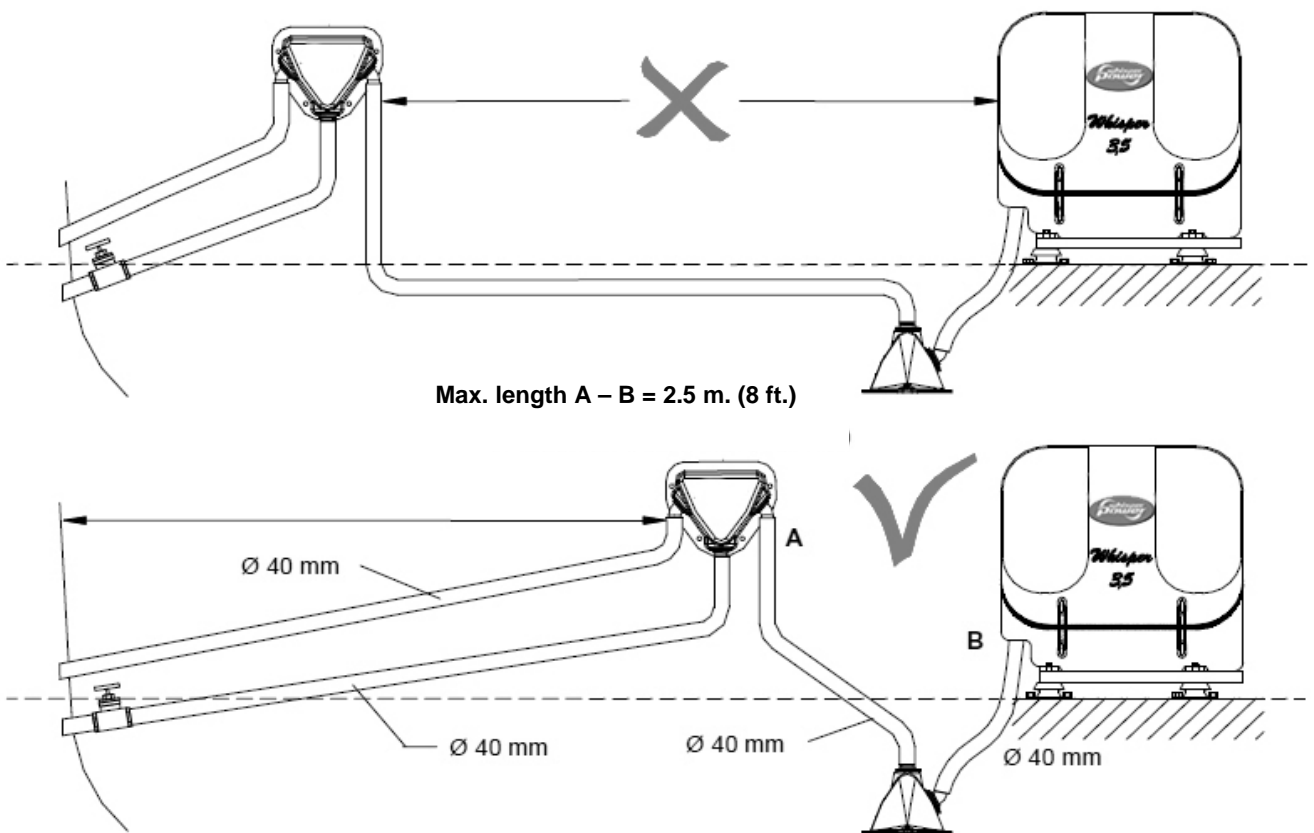

Figure 11: Only after the exhaust / water separator the exhaust hose may have a length up to 7,5m.

## 2 "SUPER SILENT" EXHAUST SYSTEM

See figure 10. In order to reduce the noise level of the generating set to a minimum, an option to reduce the exhaust noise further (especially exhaust water splashing) is an exhaust/water separator. The exhaust/water separator allows the cooling water to be ejected through a line separate from the exhaust fumes and also functions as a goose neck to prevent water from flooding the engine. The exhaust/water separator is mounted more than 60 cm above the water level.

See figure 11. If the through-hull exhaust outlet has to be mounted far from the generating set, an exhaust/water separator must definitely be installed. (Total length of the exhaust piping from generator to top of goose neck (water separator) is more than 2,50 m.) The sea water from the separator must run down along the shortest possible path to the through-hull outlet.

Only when using an exhaust /water separator the exhaust may have a length up to 7,5m after the water/gasseparator.

However watertraps should be avoided as the fumes still contains water and this should not accumulate in bents (refer to figures 12 and 13). An additional outlet exhaust muffler close to the hull outlet will help further to reduce noise emission.

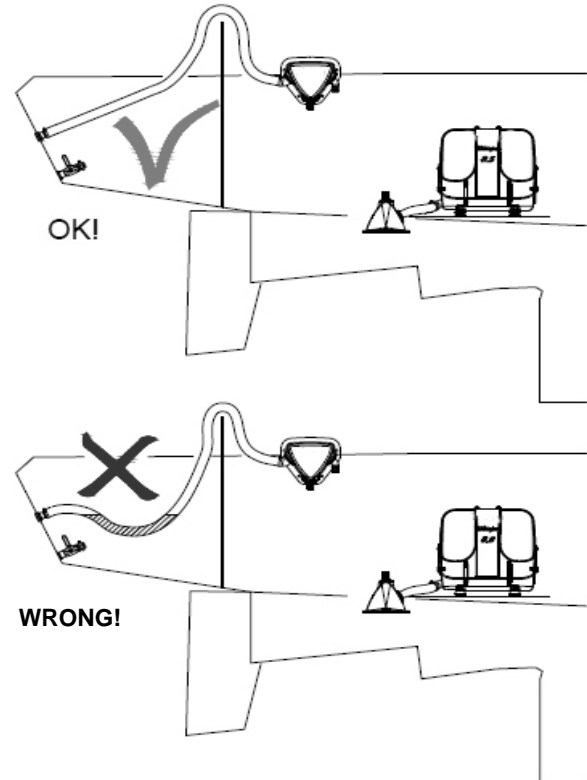

Fig. 12: Water trap in exhaust system

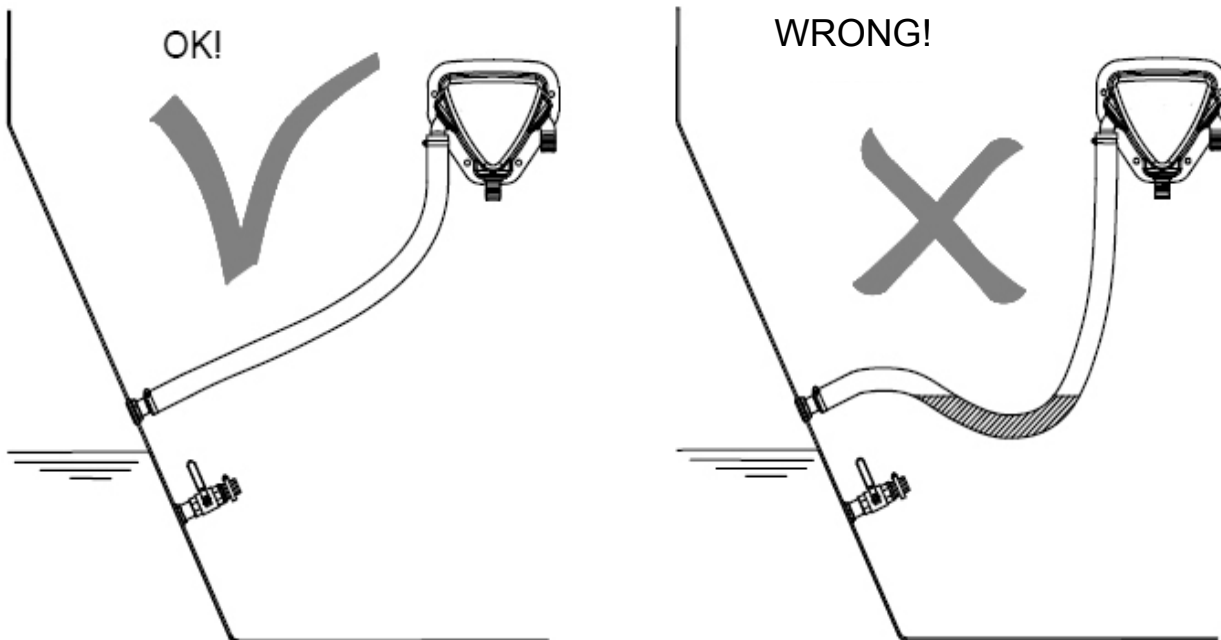

Figure 13: Water will collect in the hanging bend of the exhaust gas hose and will cause back pressure

If the generating set and the exhaust system have been installed correctly, neighbouring boats will not be disturbed by generating set noise, With the "super silent" exhaust system, generating set noises are almost inaudible. For optimal noise reduction, the sea water outlet from the exhaust/water separator (center outlet on the unit) should be installed below the water level to eliminate noisy splashing of the effluent sea water.

The through-hull outlet for the exhaust fumes should not direct the fumes directly toward the water surface as this will cause excessive noise (refer to figure 14).

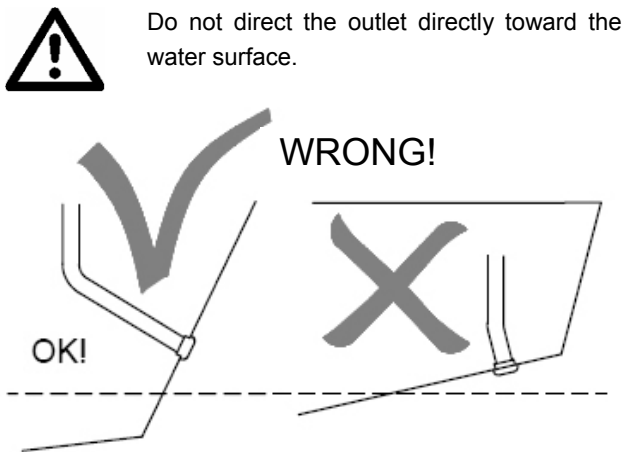

Figure 14

#### 1.4.4 Control system

##### 1 DC CONTROL SYSTEM

The electrical control system is standard in 12 Volt with negative earth. Non- earth return is available as an option for aluminium vessels to prevent corrosion.

All electrical wiring has been prepared on the generating set prior to despatch from the factory. Operation of the engine is controlled by a microprocessor based control system called "Digital Diesel Control". The Digital Diesel Control Panel is integrated in the generating set.

##### MasterBus

The generating set is compatible with MasterBus: a fully decentralized data network for communication between the different Whisper Power system devices such as the inverter, battery charger, generator, batteries and many more. See chapter 4 for details

The generating set as well as the rest of the electrical system can be monitored and controlled by any MasterBus compatible remote control panel. The MasterView Easy is a MasterBus compatible monitoring and control panel that is standard included in the delivery of the generating set.

##### Important to know:

This generating set is only feasible for the connection of MasterBus compatible remote control panels. Connection

of other remote control panels such as the *Digital Diesel Control panel*, the *System Manager AC + Whisper panel* and the *Power System Control Panel* is not possible. The Masterview Easy must be mounted on an easy accessible location, protected against rain, moist, dust and condensation. For good visibility avoid installing the panel in direct sunlight.

##### Installation of the MasterView Easy

Below mentioned steps describe a basic installation of the MasterView Easy in combination with the generating set. Refer to the separate user's manual of the Masterview Easy if you want to add any other Mastervolt system devices to the MasterBus network (see [www.whisperpower.eu](http://www.whisperpower.eu)).

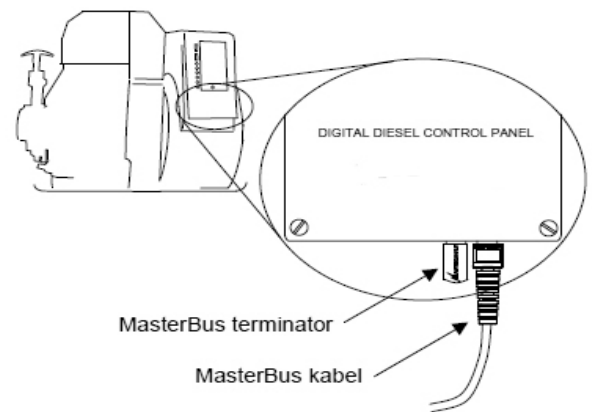

Figure 15

- 1 See figure 15 Insert a MasterBus terminating device into one of both communication ports (it doesn't matter which one) of the Digital Diesel Control Panel on the generating set. Insert the communication cable in the other communication port.

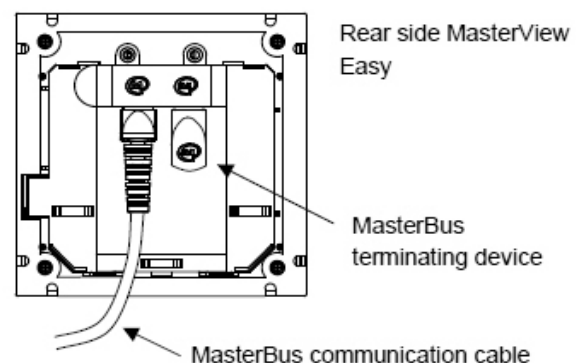

Figure 16

- 2 See figure 16. Connect the other end of the communication cable to one of both communication ports of the MasterView Easy.

Insert a MasterBus terminating device into the other communication port.

- 3 The Masterview Easy can be flush mounted or panel mounted on a wall or board:

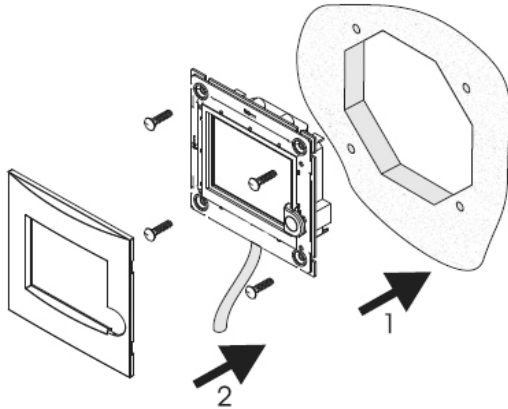

Figure 17

- Flush mounting (see figure 17):
  - Remove the outer housing and remove the front from the panel.
  - Make a cut out in the mounting wall and drill the holes using the saw template in the box or using the dimensions at the back of the front plate.
  - Mount the MasterView Easy onto the panel (1) and then reattach the front (2).
- Panel mounting (see figure 18):
  - Remove the outer housing and remove the front.
  - Drill the holes using the dimensions at the back of the front plate and fasten the outer housing (1).
  - Click the panel into the outer housing (2).
  - Reattach the front (3).

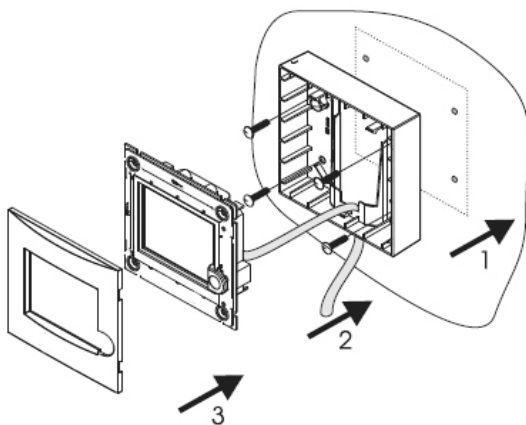

Figure 18

During first commissioning the generator set will be recognized by the MasterBus network automatically. This may take a few seconds. Then the Masterview Easy will show the initial screen.

Refer to the operation manual of the MasterView Easy for initial settings and operating instructions.

#### Event based commands

One of the main features of MasterBus is the possibility of programming for interactive operation of the connected devices, including automatic starting and stopping of the generator set. This is done by means of *event based commands*. Refer to the operation manual of the MasterView Easy for details about programming these *event based commands*.



**Whisper Power cannot be held responsible for damage caused by unattended running of the generator due to the use of event based commands.**



**Using event based commands the generator can start unexpectedly. When working on the electrical system, the 30 Amp fuse must be removed from the Local Control Panel and the battery plus cable must be removed from the battery.**

#### Connection of an emergency stop / fire alarm switch

To connect an emergency stop button or to stop the generator automatically in case of a fire alarm, you can use the bypass connection between wires 13 and 14 that come from the The Digital Diesel Control Panel. See fig. 19. To do so, remove the top cover plate of the connection box to get access to the wiring loom.

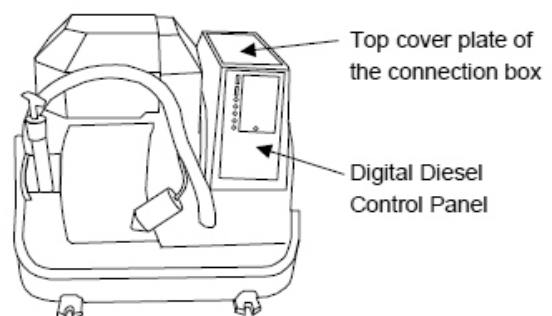

Figure 19: Location of the connection box

Disconnect the bypass between wires 13 and 14 and then replace it by an emergency switch or a potential free fire alarm switch with normally closed contacts (figure 20).



Fig. 20: Connection for emergency stop / fire alarm switch

## 2 STARTER BATTERY

For starting, the Whisper requires a 12V starter battery with the following capacity:

Model	Minimum capacity
M-SC3.5	55Ah

The generating set can be connected with the main engine battery or have its own battery. We strongly recommend the use of a separate battery for the generating set and to keep the wiring system for the propulsion engine and the domestic DC supply system completely separate and individually connected to separate batteries.

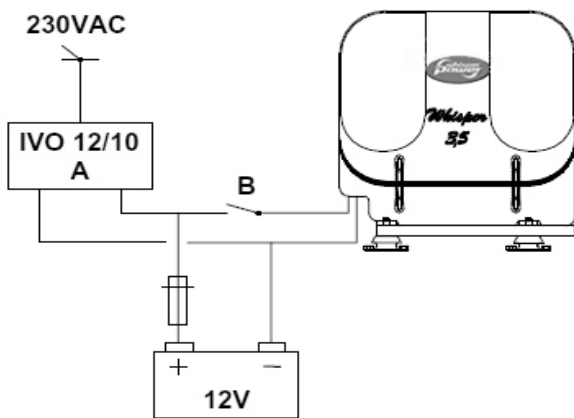

Figure 21: Installation of a starter battery

However, the negative of all the batteries on the vessel should be interconnected (when on earth) to avoid difference in the voltage level of the earth on different places causing trouble to electronic devices which might be in the system.

The above recommendation is not valid for ships having the starter battery of the propulsion engine or other auxiliary equipment positive grounded. When this is the case an expert should be consulted.

A battery switch may be used.

The starter battery is charged by the standard internal charger in the alternator. An additional battery charger will help to keep the battery in good condition when the generating set is not used. A battery charger is not

included in the standard supply. A high efficiency battery charging unit can be ordered from Mastervolt which is able to charge both the ship's main battery and the starter battery. Also a small charger can be used to charge the starter battery only, such as the IVO SMART 12/10.

## 3 OTHER RECOMMENDATIONS AND WARNINGS

The battery should be secured for seagoing conditions and the terminals should be insulated. For extra safety the battery can be enclosed in a wooden, plastic, Fibreglas etc. (non metal) box. Even when the earth return system is applied a negative battery cable should be used and the vessel should not to be used as a conductor.

In the negative battery cable a 250 Amp starter battery switch could be applied to switch off the battery. The battery cables are supplied in a standard length of 1.5 m, if longer cables are required a larger cross sectional area should be considered to compensate for voltage reduction. When two batteries are used in series to provide a 24 Volt supply system, never take off 12 Volt (starting) power from one of these batteries (figure 22). This will result in severe damage to the batteries within a short time.

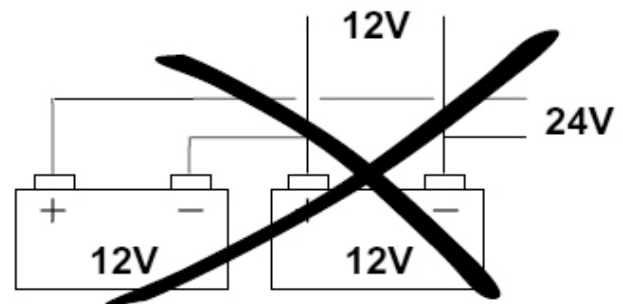

Figure 22

Disconnect the battery leads if electrical welding is to be carried out, otherwise damage will be caused to the diodes of the alternator.



As explosive hydrogen gases are discharged during charging, the battery should be located in a well ventilated room. Ensure that the supplied battery cable connectors are properly fitted and never remove during or shortly after charging as sparking can occur, which may ignite the hydrogen gasses.

### 1.4.5 AC power system (230 Volt)



Before working (installation) on the system read the sections on safety in the users manual.

Be sure that all electrical installations (including all safety systems) comply with all required regulations of the local

authorities. All electrical safety/shutdown and circuit breaking systems have to be installed onboard as the generating set itself cannot be equipped with such equipment for every possible variation.

The vessel's power supply system should be suitable and safe for the AC voltage which is applied and the power that will be generated. Special attention has to be paid on dividing the system in branches which are fused individually.

It is absolutely essential that each and every circuit in the on-board electrical system is properly installed by a qualified electrician.

### 1 FUSE

An output fuse (from the generating set to the system) should be installed to protect the installed electrical system. The fuse should be sized such that the rated generating set current is not exceeded by more than 15%. The maximum single phase output current is as listed below:

Model	Maximum output current
M-SC3.5 – 3000 rpm	13 Amp

The fuses must be of the slow reacting type. For electrical motors connected to the system, a motor protection switch must be installed.

### 2 GROUNDING

The AC alternator windings are not grounded. Measures against earth insulation failures are often subject to local regulations. The housing of the alternator and all other metal parts are grounded. For safety reasons connect the main ships ground to negative point of the generating set start battery. When an ungrounded return DC system or positive grounded DC system is applied the battery negative should not be connected to the main ships ground.

To make a connection between "neutral" and "ground" could be necessary as part of a specific insulation failure protection system.

Small pleasure craft in Europe is submitted to The Recreational Craft Directive 94/25/EC. The guidelines of this directive refer to (ISO 13297).

When the installation comply to this standard the "neutral" and "ground" should be connected on the generating set by connecting the blue (neutral) wire with the terminal on which the yellow/green wire is connected.



### WARNING

In all situations the transfer switches between shore, inverter and generator should switch all connections, the phase line (L) as well as neutral (N). Of course this is the case when using a Masterswitch.

Be aware that insulation protection systems can be different for different applications and even within the ship there could be different standards for different spaces. We did refer to the Recreational Craft Directive that applies to pleasure craft up to 24 m of length. Sometimes one has to comply with other standards such as the rules of certification societies like Lloyds Register of Shipping or Veritas, regulations for the protection of personal, building legislation, etc. It is of the greatest importance to have expert advice on this issue.

### 3 CABLE

For the power cable we recommend the oil resistant cable with the following cross sectional area:

Model	Cross sectional area
M-SC3.5 – 3000 rpm	3x2.5 mm <sup>2</sup> (5m. included)

For very long cables it is recommended to apply cables with a larger cross section than the mentioned above.

### 4 TRANSFER SWITCH

A power source selector switch must be installed between the generating set and the ship's electrical supply system. This switch must ensure that all AC consumers can be switched off at once. This switch should also be installed to keep the generating set and shore (grid) power systems separate.

Transfer switches - to switch over from shore to ship or from generating set to inverter - should be well designed to switch over all wires including neutral (and not only phases or line) and there should be provisions with the aid of timers to prevent relays from chattering.

Whisper Power advises the installation of a Masterswitch as the power source selector. This works automatically when the generating set is not running the input remains in the shore position and as soon as the generating set is running the Masterswitch switches automatically after 10 seconds delay time over to the generating set position.

## 2 INSTALLATION SPECIFICATIONS

### 2.1 M-SC3.5 INSTALLATION TABLE

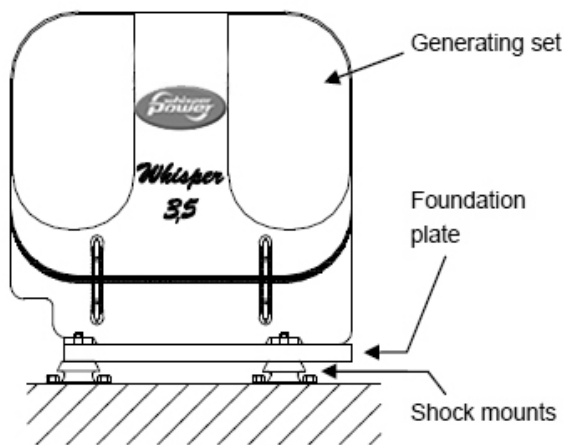

Figure 23

- 1 Install a steel foundation plate between ship's hull and generating set, with 4 shock mounts (ref. to figure. 23).
- 2 Mount the generating set directly to the foundation plate.
- 3 Connect the (sea) water inlet to the strainer.
- 4 Connect exhaust system.
- 5 Connect a siphon breaker or 'air vent' into the cooling circuit, if necessary.
- 6 Connect 'fuel supply line' to the water separator/ fuel filter.
- 7 Connect 'fuel return line' to the fuel tank.
- 8 Connect the MasterView Easy remote panel.
- 9 Connect the AC cable from the AC box to the power source selector or Mass SystemSwitch.
- 10 Connect plus and minus from the 12V starter battery to the battery cables.
- 11 Install a Whisper Power battery charger (optional).

### 2.2 COMMISSIONING TABLE

- 1 Check if a siphon breaker (air vent) is necessary and has been installed and that the drain is without bents and air can flow in freely.
- 2 Open the seawater inlet valve and check all water connections. Check if the strainer is installed above the seawater level.
- 3 Check if the exhaust system is properly installed. Also check the minimum required height of 60 cm above sea level of the exhaust loop (goose neck). Check length of exhaust hose, diameter of exhaust hose, position of the waterlock, maximum lift.
- 4 Open the seawater outlet valve and check all water connections.
- 5 Check the AC cables and the grounding.
- 6 Check if an AC breaker is installed before or after the power source selector. When there is only a circuit breaker, use it to disconnect the generating set from the grid.
- 7 Check all DC connections, check if the battery switch/ circuit breaker is closed.
- 8 Open the fuel valve and bleed the fuel system. Ensure there is sufficient fuel. The M-SC3.5 is self bleeding. To check the well functioning release the bleed screw on the high pressure fuel pump. Push the start button activating the electric system and activating the fuel pump. When more time is needed to bleed, push "start" and hold on the local control panel (so not on the MasterView Easy remote panel). Hold as long as necessary to bleed the system. Retighten the bleed screw when no further air bubbles are expelled. Check if there are no air leaks in the fuel supply line and check if the lift of the fuel is less than 1 meter. Check if there is no air in the water fuel separator.
- 9 Check if the air intake in the canopy is not blocked.
- 10 Check the oil level and color of the oil.
- 11 Start the engine by pushing the start button.



- |  |  |
|--|--|
| <p>12 Check when the generating set is running, the delay of 3 – 10 seconds in the power source selector transfer.</p> <p>13 Check voltage and frequency under 'no load' conditions.</p> <p>14 Check voltage and frequency under 'full load' conditions.</p> <p>15 Check if the battery charger of the generating set is working (max. 14.5 Volt).</p> | <p>16 Close the sound shield and check the noise level.</p> <p>17 Stop the generating set and check the engine again for leakages of oil, fuel or water.</p> <p>Installation checklist available on our website: <a href="http://www.whisperpower.eu">www.whisperpower.eu</a>.</p> <p>Commissioning form available on our website: <a href="http://www.whisperpower.eu">www.whisperpower.eu</a>.</p> |
|--|--|

## 2.3 INSTALLATION SPECIFICATIONS M-SC3.5

### TECHNICAL DATA

Article no	41200500
Dimensions WxDxH	505x400x500 mm
Weight	104 kg including sound shield
Max. operation angle	25°
Remote control	MasterView Easy (MasterBus)
Battery capacity min.	12V, 55 Ah
Fuel consumption	0,7-1,5 l/hr, load dependent
Lift fuel pump	electric driven 12 V DC, max. lift 1 m
Cooling	indirect cooling
Cooling pump	raw water Whisper Power self priming impeller pump, PTO driven, type K
Minimum water supply	8-10 l/min.
Crank case lube oil capacity	1.3 litre + 0.2 oil cooler, total 1.5 litre
Alternator	synchronous brushless, maintenance free water cooled
Voltage regulation	capacitor
Output power	230V/50Hz : 3kWatt @ cos phi = 1
Battery charger	additional 12V winding including regulator (4 Amps)

### 2.4 SPECIFICATION OF THE ACCESSORIES

Water scoop	min. 1/2" (recommended 3/4")
Inlet valve	min. 1/2" in 12.5 mm out (recommended 3/4" in 12.5 mm out)
Water strainer	12.5 mm in, 12.5 mm out
Air vent	12.5 mm
Inlet suction hose	12.5 mm
Fuel filter/water separator	30 micron
Fuel inlet and return	8 mm
Exhaust hose in/out	Ø 40 mm (1 5/8")
Water lock	Ø 40 mm (1 5/8")
Water/gas separator	Ø 40 mm (1 5/8")
Anti shock mounts	art. nr. 50230552
Foundation plate	min. 44 kg (97 Lbs)
Battery charger (optional)	IVO SMART 12/10; 12V / 10 Amps

## 2.5 INSTALLATION MATERIALS M-SC3.5

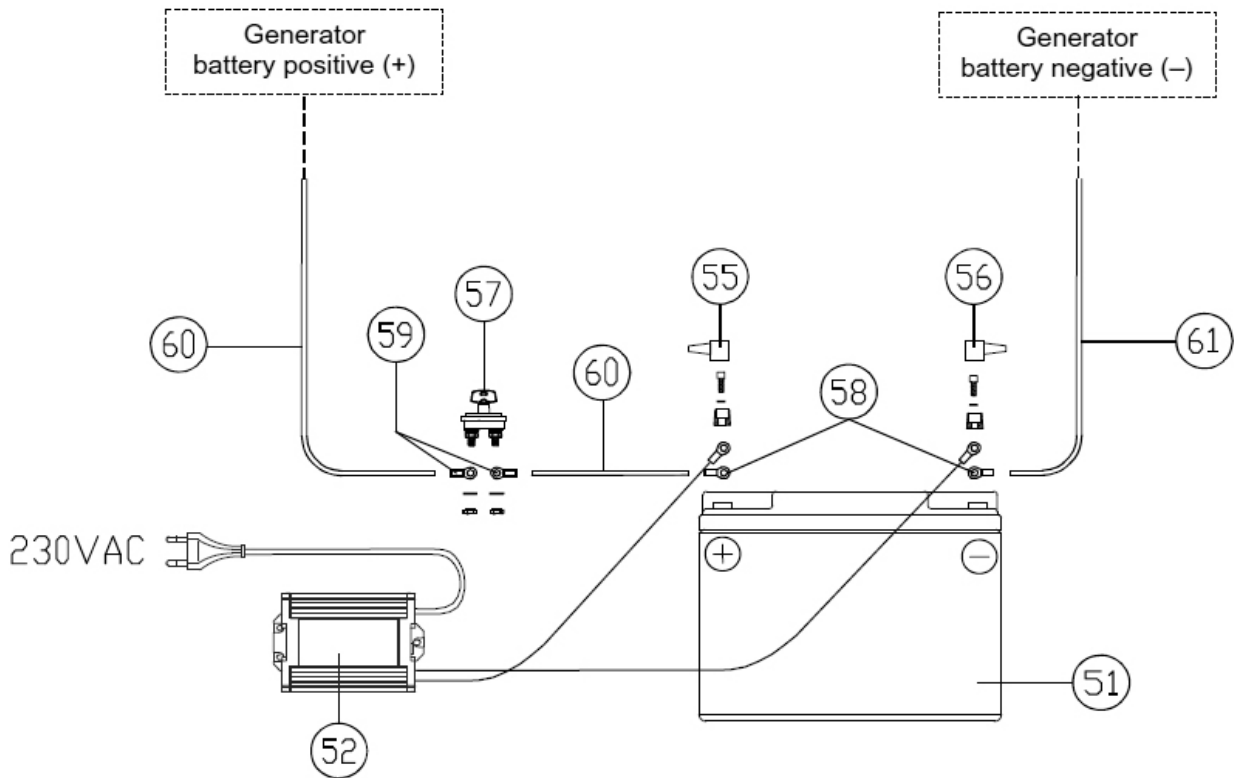

Figure 24: Installation materials battery installation kit

### BATTERY INSTALLATION KIT 55 Ah

pos.	qty	article no	description	
51	1	64000550	Whisper Power 12/55 Ah AGM Battery	
52	1	43011000	IVO Smart 12/10 230V/50-60Hz IP65 battery charger	
55	1	68230302	Terminal Cover RED 230N3V02	
56	1	68230314	Terminal Cover BLACK 230N3V14	
57	1	79006005	Battery switch ON/OFF with key 250A	
58	2	6503001606	Cable lug 16mm <sup>2</sup> / M6	
59	2	6503001610	Cable lug 16mm <sup>2</sup> / M10	
<b>TOTAL</b>		<b>50230208</b>	<b>BATTERY INSTALLATION KIT 55Ah</b>	

### OPTIONAL INSTALLATION MATERIALS

- Additional installation parts

pos.	qty	article no	description	
60		6501208010	Cable 16mm <sup>2</sup> red	per 100 meter
61		6501208020	Cable 16mm <sup>2</sup> black	per 100 meter

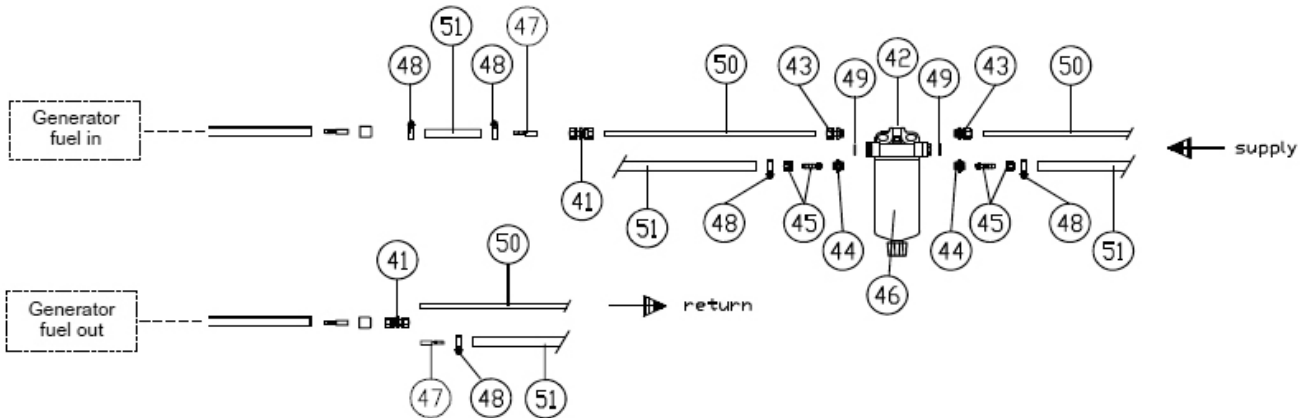

Figure 25: Installation materials fuel supply kit

**FUEL SUPPLY KIT**

pos.	qty	article no	description	
41	2	50221203	Straight coupling 8 mm	
42	1	50230091	Filter head strainer fuel/water separator	
43	2	50221618	Parallel male coupling M14- 8 mm	
44	2	50221619	Parallel male coupling M14- 10 mm	
45	2	50221620	Hose connection 8 mm outer cone	
46	1	50230092	Filter for strainer fuel/water separator	
47	2	50221252	Nipple hose pipe 8-8	
48	4	50221522	Hose clamp stainless 10-16	
49	2	50221632	Copper gasket ring 18x14x1,5 mm	
<b>TOTAL</b>		<b>50230205</b>	<b>FUEL SUPPLY KIT</b>	

Note: fuel pipes / fuel hoses are not included in the delivery of the fuel supply kit.

**OPTIONAL INSTALLATION MATERIALS**

## • Additional installation parts

pos.	qty	article no	description	
48		50221522	Hose clamp stainless 10-16	
50		50222020	Copper fuel pipe	per meter
51		50220063	Fuel hose	per meter

**OPTIONAL INSTALLATION MATERIALS**

## • Additional installation parts

pos.	qty	article no	description	
46		50230092	Filter for strainer fuel/water separator	

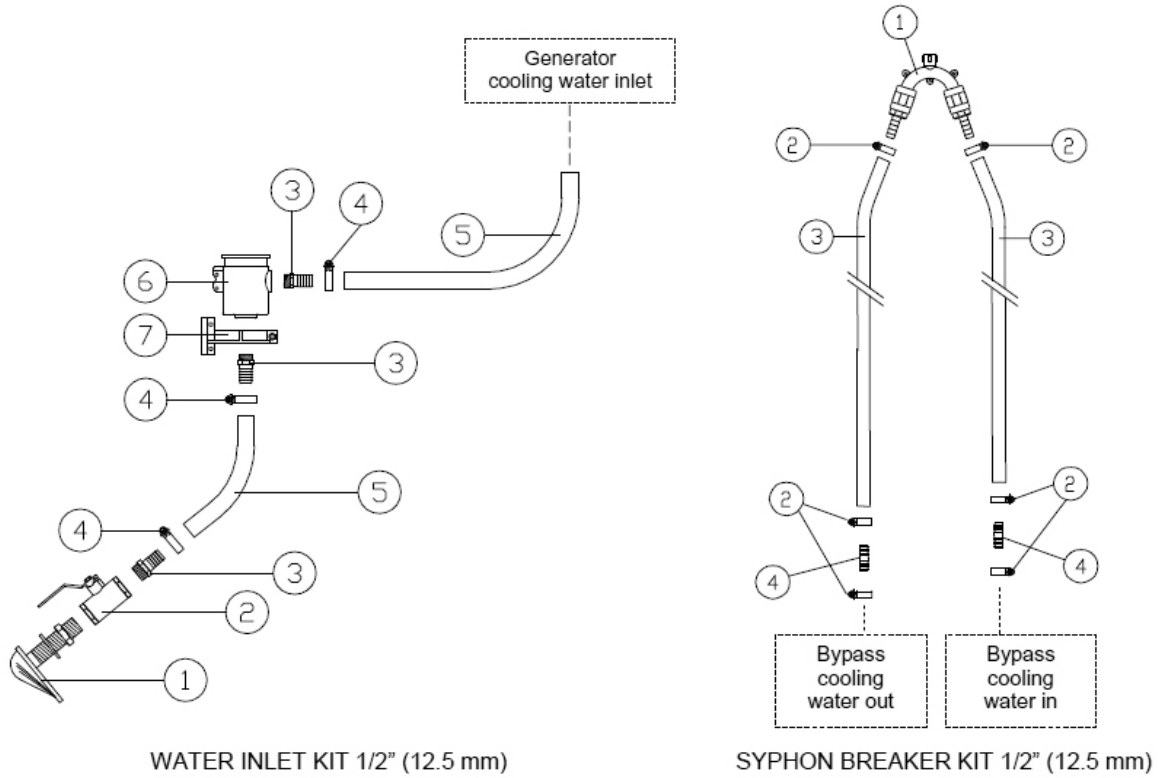

Figure 26: Installation materials Water inlet kit and Syphon breaker kit

**WATER INLET KIT 12.5 mm**

pos.	qty	article no	description
1	1	50230052	Intake strainer 3/4"
2	1	50230042	Lever operated ball valve FF 3/4"
3	3	50221016	Male hose connection 3/4"x13
4	3	50221521	Hose clamp stainless 12-20
5	3m	50220055	Cool. water hose transp.spiral 13x19mm
6	1	50230062	Nickel plated brass intake strainer 3/4"
7	1	50230067	Mouting bracket small waterstrainer 1158
<b>TOTAL</b>		<b>50230201</b>	<b>WATER INLET KIT 12.5 mm</b>

**SYPHON BREAKER KIT 12.5 mm**

pos.	qty	article no	description
1	1	50230017	Syphon breaker valve 12.5mm (1/2"), complete (including valve assembly)
2	6	50221521	Hose clamp stainless 12-20
3	3m	50220057	Cooling water hose warm water 13x21mm
4	2	50221260	Hose connector 12.5mm (1/2")
<b>TOTAL</b>		<b>50230272</b>	<b>SYPHON BREAKER KIT 12.5 MM (1/2")</b>

According to ABYC recommendations all hose connections must be fitted with two hose clamps  
Maximum torque hose clamps: 12Nm / 105 InLbs

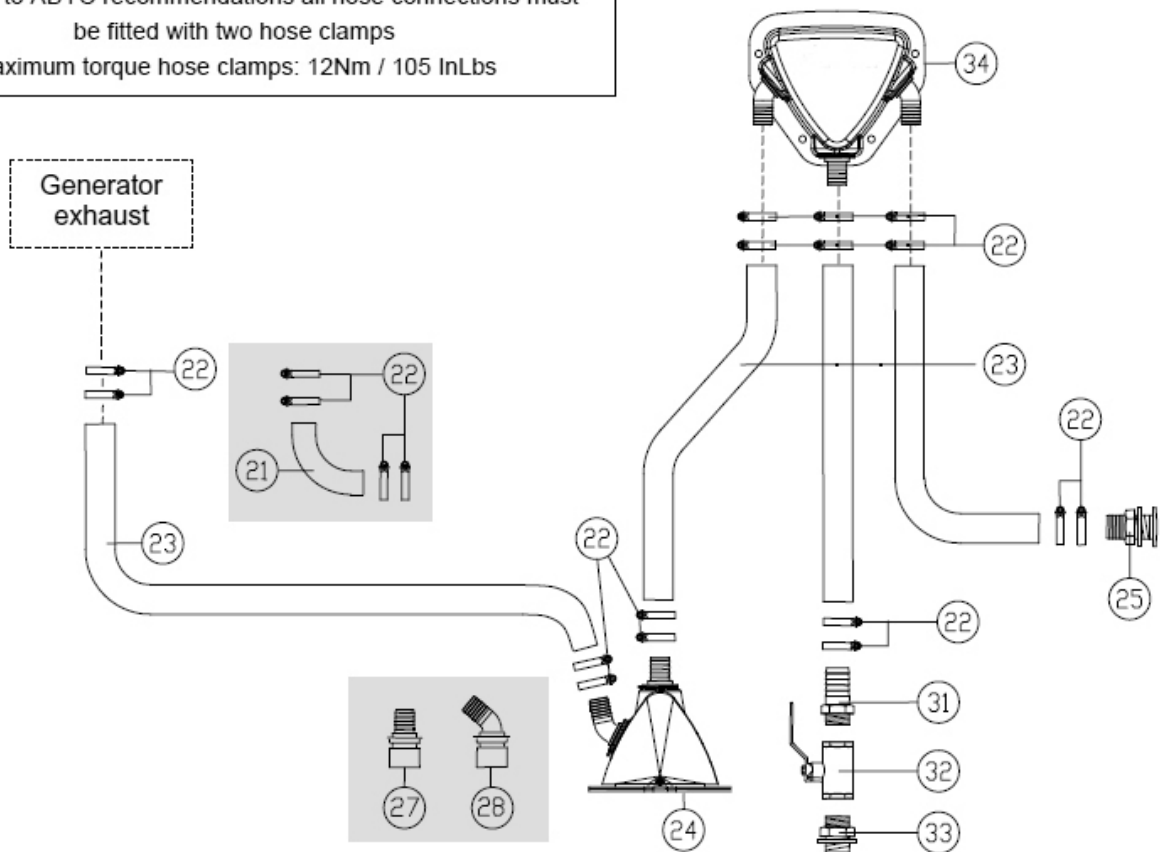

Figure 27: Installation materials "Delta" exhaust kit  $\varnothing$  40 mm (1 5/8") and water separator kit 40 mm (1 5/8")

#### "DELTA" EXHAUST KIT $\varnothing$ 40 mm (1 5/8")

pos.	qty	article no	description
22	8	50221504	Hose clamp stainless 32-44 mm
23	3m	50220033	Marine exhaust hose 40 mm (1 5/8")
24	1	50230093	Waterlock 40 mm Delta
25	1	50230038	Brass hull fitting hose connection 1 1/4"x40
<b>TOTAL</b>		<b>50230251</b>	<b>DELTA EXHAUST KIT 40 mm</b>

#### "DELTA" WATERSCHIEDER KIT 40 mm (1 5/8")

pos.	qty	article no	description
22	8	50221504	Hose clamp stainless 32-44 mm
23	2,5m	50220033	Marine exhaust hose 40 mm (1 5/8")
31	1	50221015	Male hose connection 1 1/4" x 40mm
32	1	50230044	Lever operated ball valve FF 1 1/4"
33	1	50230033	Brass through hull fitting 1 1/4" x 70
34	1	50230097	Water / gas separator Delta 40/40/40mm (1 5/8")
<b>TOTAL</b>		<b>50230261</b>	<b>DELTA WATER/GAS SEPARATOR KIT 40 mm</b>

#### OPTIONAL INSTALLATION MATERIALS

##### • Aanvullende installatiematerialen

pos.	qty	article no	description
21	1	50201830	Elbow 90° adapter exhaust hose
22	4	50221504	Hose clamp stainless 32-44 mm
27	1	50230113	Straight coupling Delta 40mm
28	1	50230112	Elbow (45°) Delta 40mm

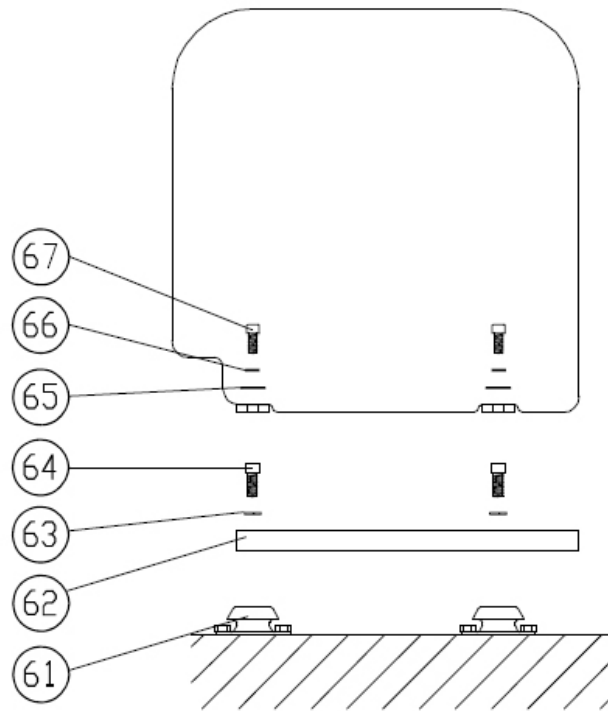

Figure 28: installation materials base plate kit

**BASE PLATE KIT for M-SC3.5 (3000 rpm)**

pos.	qty	article no	description
61	4	50230552	Rubber mounting up to 70 kg RAB3
62	1	50230012	HD base plate 3500 yellow zinc plated
63	4	50211449	Washer spring SP M12
64	4	50211251	Bolt hexagonal socket ZP M12x40
65	4	50211438	Washer SP M10x30x1,5
66	4	50211447	Washer spring SP M10
67	4	50211241	Bolt hexagonal socket ZP M10x25
<b>TOTAL</b>		<b>50230207</b>	<b>BASE PLATE KIT M-SC3.5</b>

### 3 DIAGRAMS & DRAWINGS

#### 3.1 DC WIRING DIAGRAM

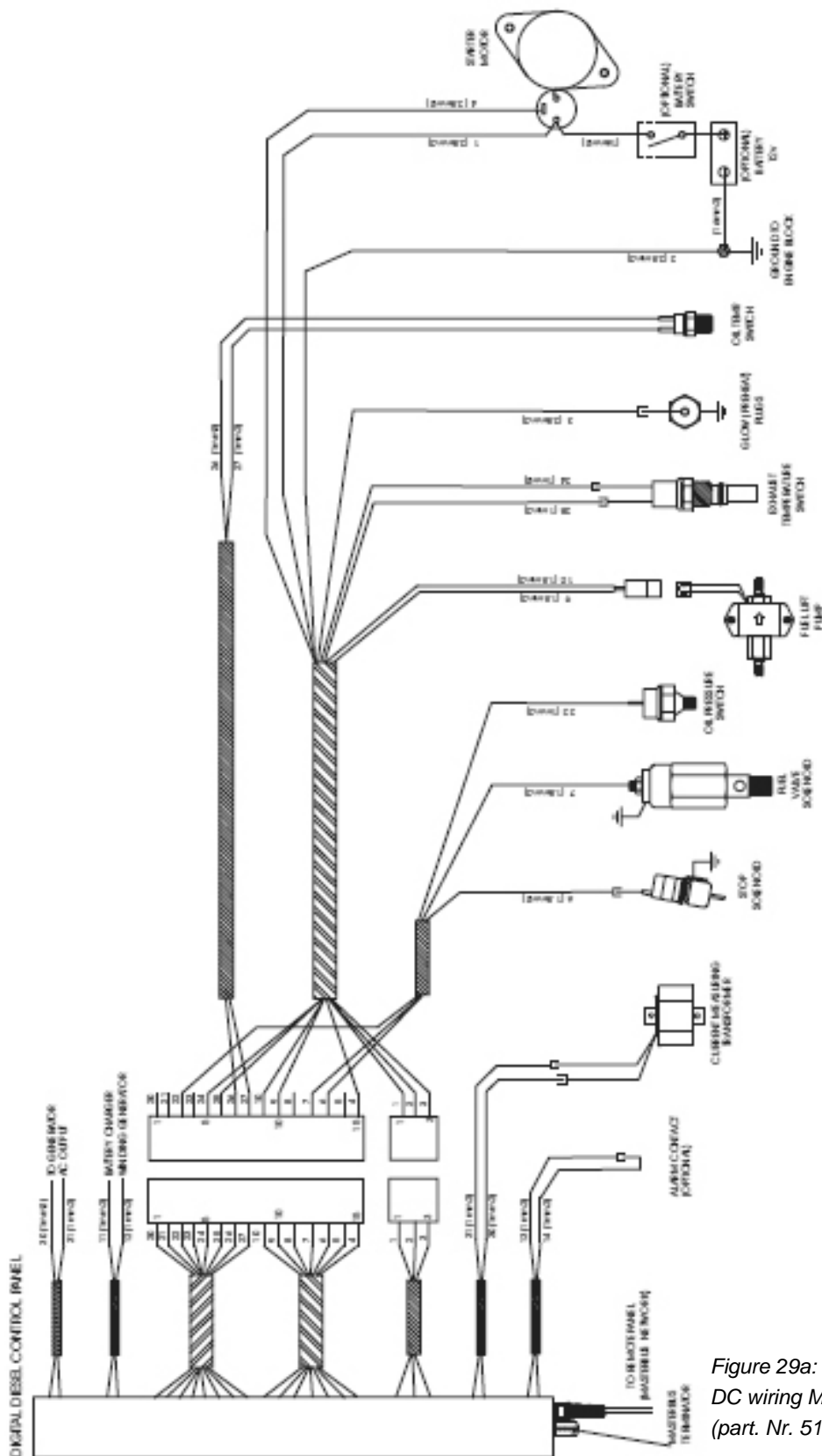

Figure 29a:  
DC wiring M-SC3.5 grounded  
(part. Nr. 51200500)

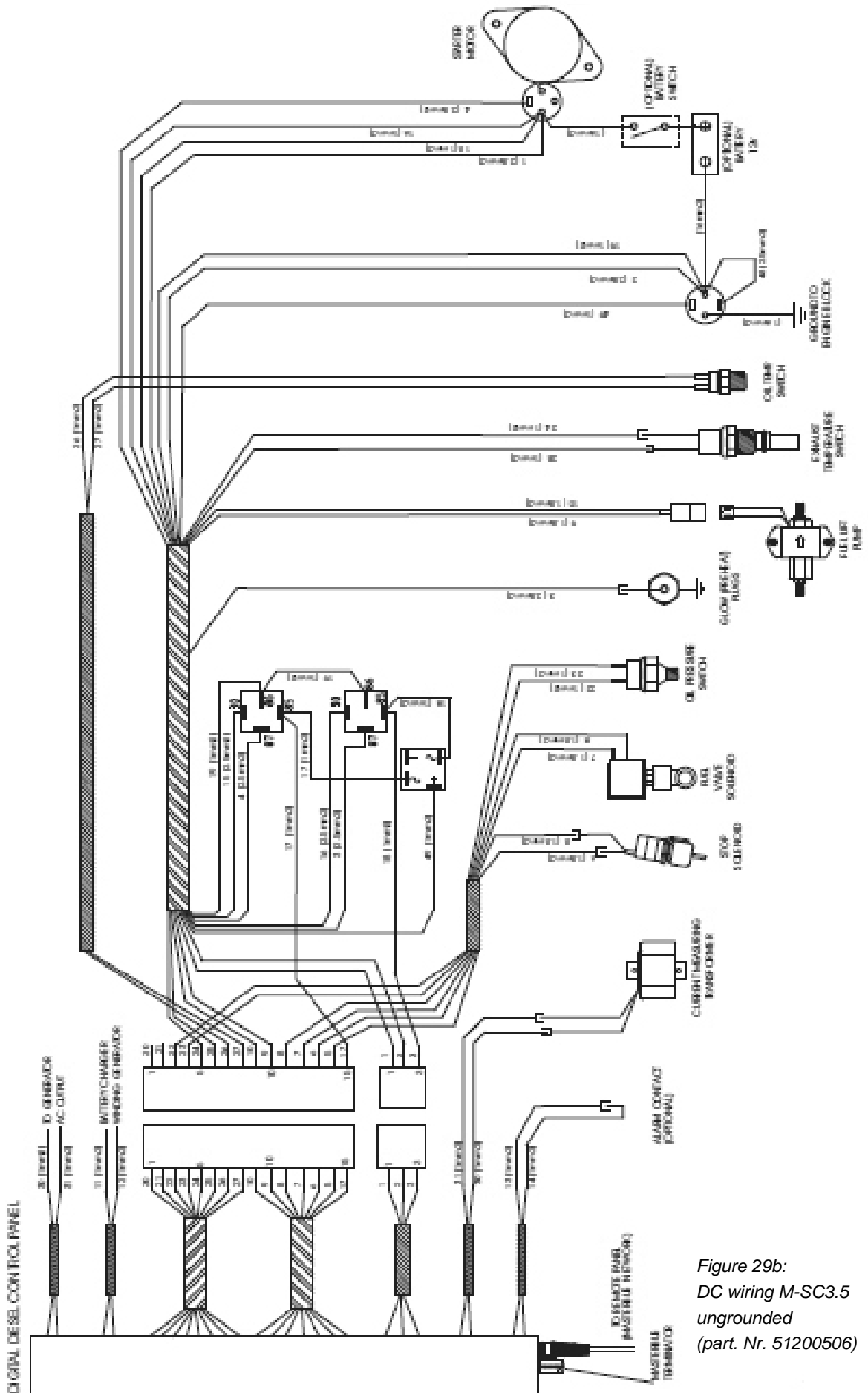

Figure 29b:  
DC wiring M-SC3.5  
ungrounded  
(part. Nr. 51200506)



### 3.2 WIRING NAMES AND COLOURS

Wire name	Wire number	Colour	Cross section
Battery +	1	White	2.5 mm <sup>2</sup>
Battery -	2	White	2.5 mm <sup>2</sup>
Glow +	3	White	2.5 mm <sup>2</sup>
Start solenoid +	4	White	2.5 mm <sup>2</sup>
Stop solenoid -	5*	White	2.5 mm <sup>2</sup>
Stop solenoid +	6	White	1.5 mm <sup>2</sup>
Fuel valve +	7	White	1.5 mm <sup>2</sup>
Fuel valve -	8	White	1.5 mm <sup>2</sup>
Fuel pump +	9	Brown	1.5 mm <sup>2</sup>
Fuel pump -	10	Black	1.5 mm <sup>2</sup>
Charger a	11	White	1 mm <sup>2</sup>
Charger b	12	White	1 mm <sup>2</sup>
Safety switch +	13	White	1 mm <sup>2</sup>
Safety switch -	14	White	1 mm <sup>2</sup>
Battery +	15*	White	2.5 mm <sup>2</sup>
Battery +	16*	White	2.5 mm <sup>2</sup>
Start relay +	17*	White	1 mm <sup>2</sup>
Glow relay +	18*	White	1 mm <sup>2</sup>
Battery -	19*	White	1 mm <sup>2</sup>
Oil pressure +	22	White	1 mm <sup>2</sup>
Oil pressure -	23*	White	1 mm <sup>2</sup>
Exhaust temp. +	24	White	1 mm <sup>2</sup>
Exhaust temp. -	25	White	1 mm <sup>2</sup>
Engine temp. +	26	White	1 mm <sup>2</sup>
Engine temp. -	27	White	1 mm <sup>2</sup>
Iac1-L	30	White	1 mm <sup>2</sup>
Iac1-N	31	White	1 mm <sup>2</sup>
Uac1-L	40	White	1 mm <sup>2</sup>
Uac1-N	41	White	1 mm <sup>2</sup>
Ground relay +	49*	White	1 mm <sup>2</sup>
Battery +		Red	16 mm <sup>2</sup>
Battery -		Black	16 mm <sup>2</sup>
Earth wire		Green/yellow	6 mm <sup>2</sup>

\* Ungrounded versions only (part nr. 51200506)

### 3.3 AC WIRING DIAGRAM 230V / 50HZ

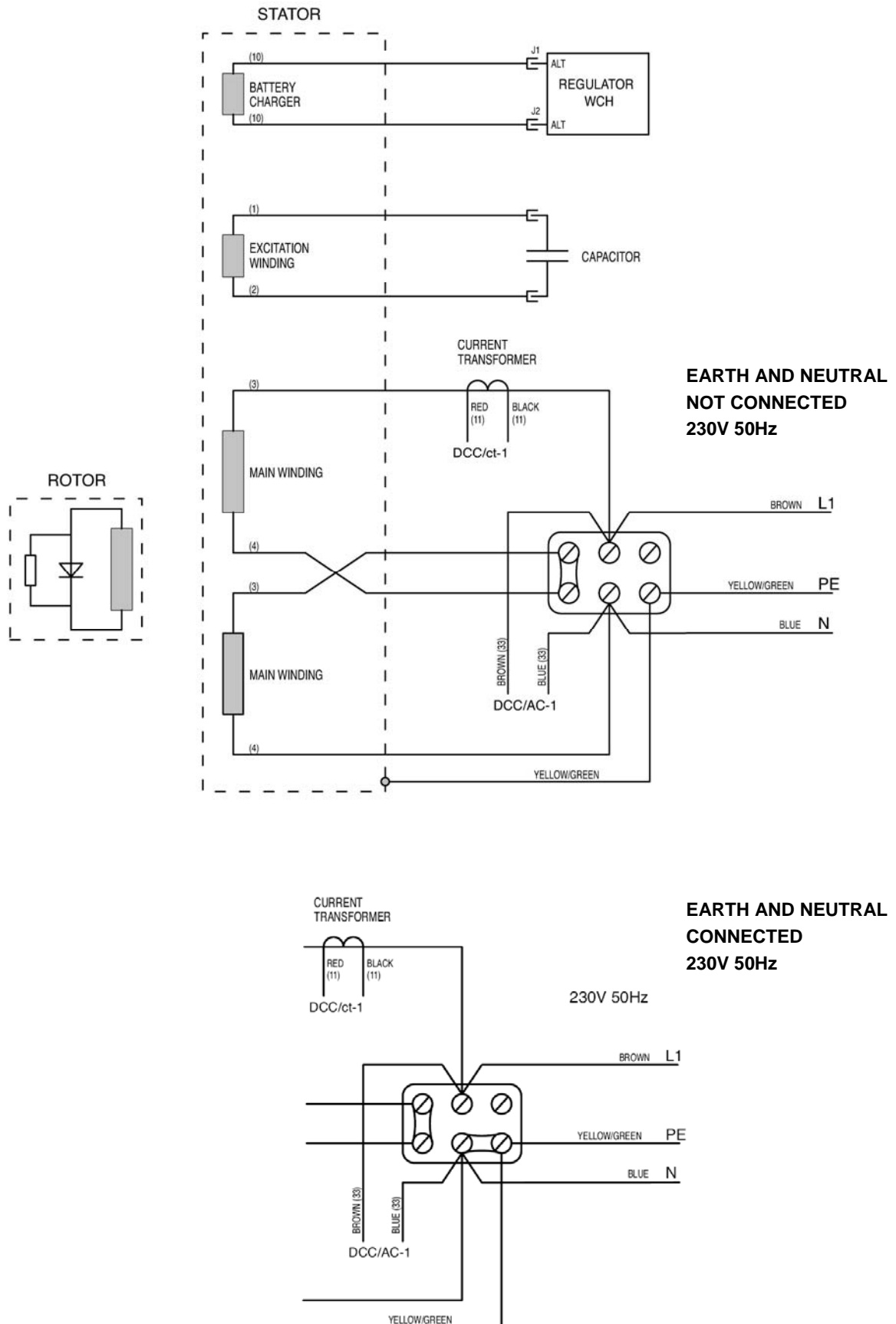

Figure 30 AC wiring diagram

### 3.4 DIMENSIONS MASTERVIEW EASY PANEL

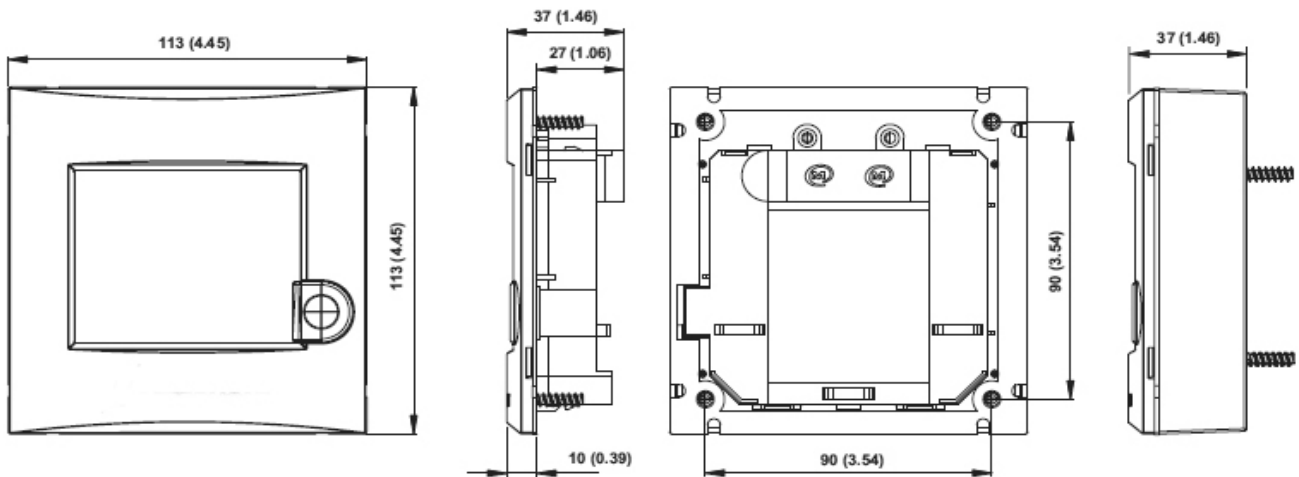

Figure 31: Dimensions of the panel without and with outer casing. All dimensions are in mm (inch)

### 3.5 DIMENSIONS M-SC3.5

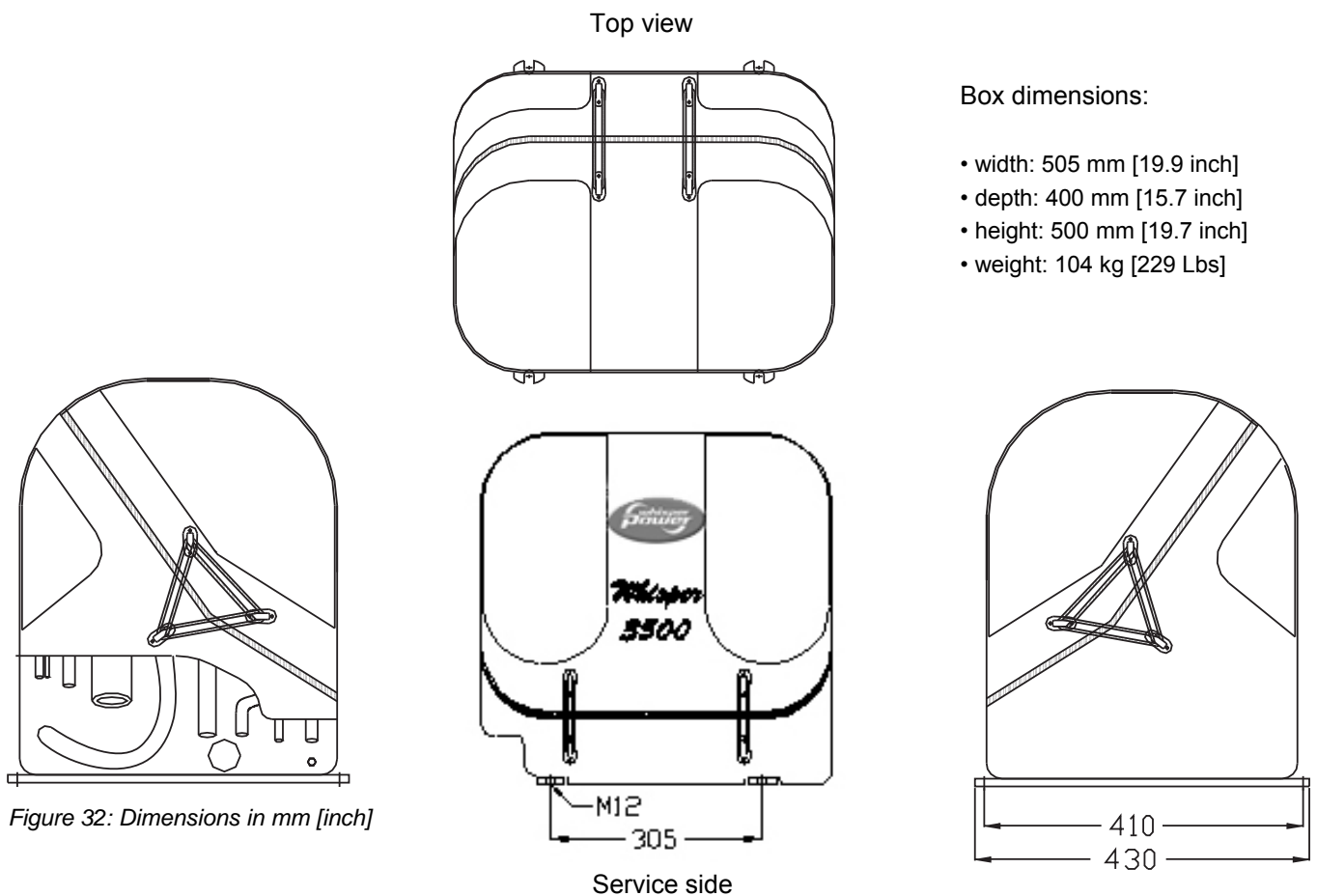

Figure 32: Dimensions in mm [inch]

#### CONNECTIONS

• exhaust:	40 mm	• battery +:	16 mm <sup>2</sup> red (included)
• fuel hose:	8 mm	• battery -:	16 mm <sup>2</sup> black (included)
• sea water in:	13 mm	• cables:	3x 2.5 mm <sup>2</sup> (5 meter included)
• air vent connection:	13 mm	• remote control:	MasterBus communication cable (15 meter included)

## 4 MASTERBUS

### 4.1 WHAT IS MASTERBUS?



All devices that are suitable for MasterBus are marked by the MasterBus symbol.

MasterBus is a fully decentralized data network for communication between the different Mastervolt system devices. It is a CAN-bus based communication network which has proven itself as a reliable bus-system in automotive applications. MasterBus is used as power management system for all connected devices, such as the inverter, battery charger, generator and many more. This gives the possibility for communication between the connected devices, for instance to start the generator when the batteries are low.

MasterBus reduces complexity of electrical systems by using UTP patch cables. All system components are simply chained together. Therefore each device is equipped with two MasterBus data ports. When two or more devices are connected to each other through these data ports, they form a local data network, called the MasterBus. The results are a reduction of material costs as only a few electrical cables are needed and less installation time.

For central monitoring and control of the connected devices Whisper Power offers a wide range of panels which show full status information of your electrical system at a glance and a push of a button. Four different panels are available, from the small Mastervision compatible 120 x 65mm LCD screen up to the full colour MasterView System panel. All monitoring panels can be used for

monitoring, control and configuration of all connected MasterBus equipment.

New devices can be added to the existing network in a very easy way by just extending the network. This gives the MasterBus network a high degree of flexibility for extended system configuration, not only today, but in the future as well!

Whisper Power also offers several interfaces, making even non-MasterBus devices suitable to operate in the MasterBus network.

### 4.2 EVENT-BASED COMMANDS

With MasterBus each device can be programmed to initiate an action at an other connected device. This is done by means of *event based commands*.

Example: if the state of charge of the service batteries is at 40%, the generator must be started.

In this example, the MasterBus network should at least exist of the following *devices*: a *MasterView Easy* panel for programming of event based commands, a *MasterShunt* to measure the state of charge of the service batteries and a *Whisper generator* set as power supply for the battery charger.

As the state of charge of the service batteries is measured by the *MasterShunt*, this device is considered as the *Event source*. The *Whisper generator* set is the device that should initiate an action (starting the generator to charge the service batteries), and is therefore considered to be the *target*. This means that you should use the *MasterView Easy* panel to program the *MasterShunt* as follows:

Event source:	Battery pre low	Select from <i>list of events sources</i> (see manual of the <i>MasterShunt</i> )
Event target:	GEN M-SC3.5	Select from the <i>device list</i> (devices connected to the MasterBus)
Event command:	Auto start	Select event command from the <i>list of event commands</i> of the target (see manual of the of the <i>Generator</i> )
Event data:	Copy	Select event action from the <i>list of event commands</i> of the target (see manual of the of the <i>Generator</i> )

### 4.3 HOW TO SET UP A MASTERBUS NETWORK

Each device that is suitable for the MasterBus network is equipped with two data ports. When two or more devices are connected to each other through these ports, they form a local data network, called the MasterBus.

Keep the following rules in mind:

Connections between the devices are made by standard straight UTP patch cables. Whisper Power can supply these cables. These cables are also commonly available at computer supply stores.

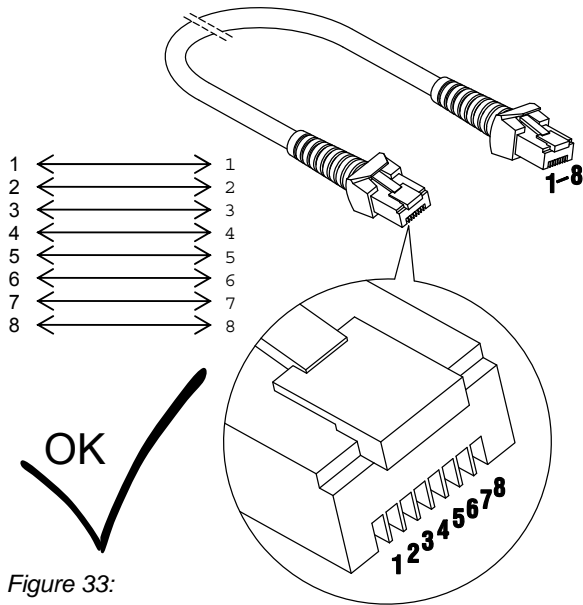

Figure 33:

As with all high speed data networks, MasterBus needs a terminating device on both ends of the network.

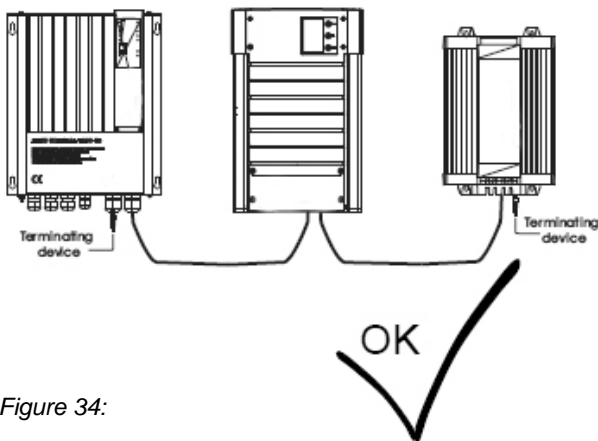

Figure 34:

The electric power for the network comes from the connected devices.

At least one device in the network should have powering capabilities (see specifications).

One powering device can power up to three nonpowering devices. As all powering devices are galvanically isolated, multiple powering devices are allowed.

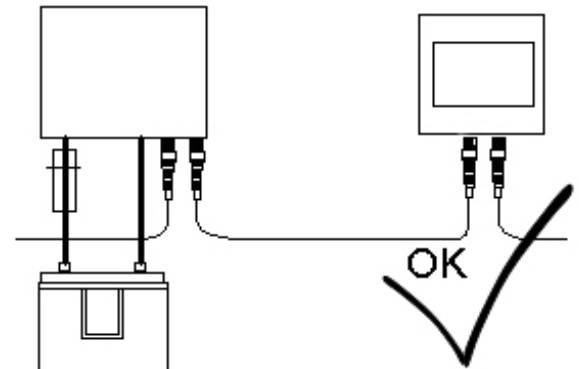

Figure 35:

Do not make ring networks.

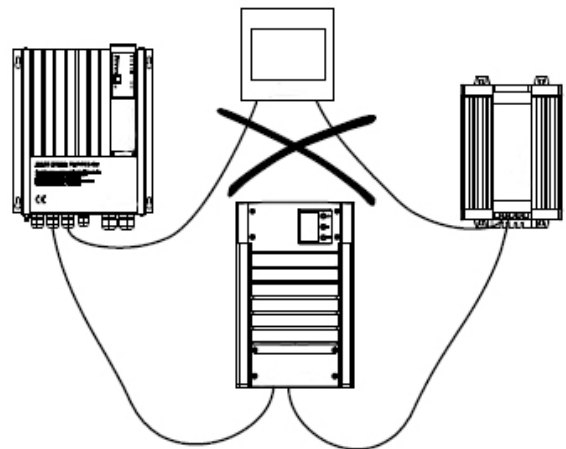

Fig. 36:

Do not make T-connections in the network.

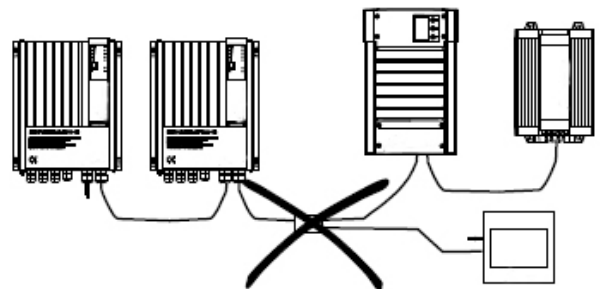

Figure 37:

## NOTES

---

---

---

---

---

---

---

---

---

---

---

---

---

---

---

---

---

---

---

---

---

---

---

---



Kelvinlaan 82, 9207 JB Drachten, Netherlands  
Tel : + 31-512-571550 / Fax : + 31-512-571599  
[www.whisperpower.eu](http://www.whisperpower.eu) / [info@whisperpower.nl](mailto:info@whisperpower.nl)