

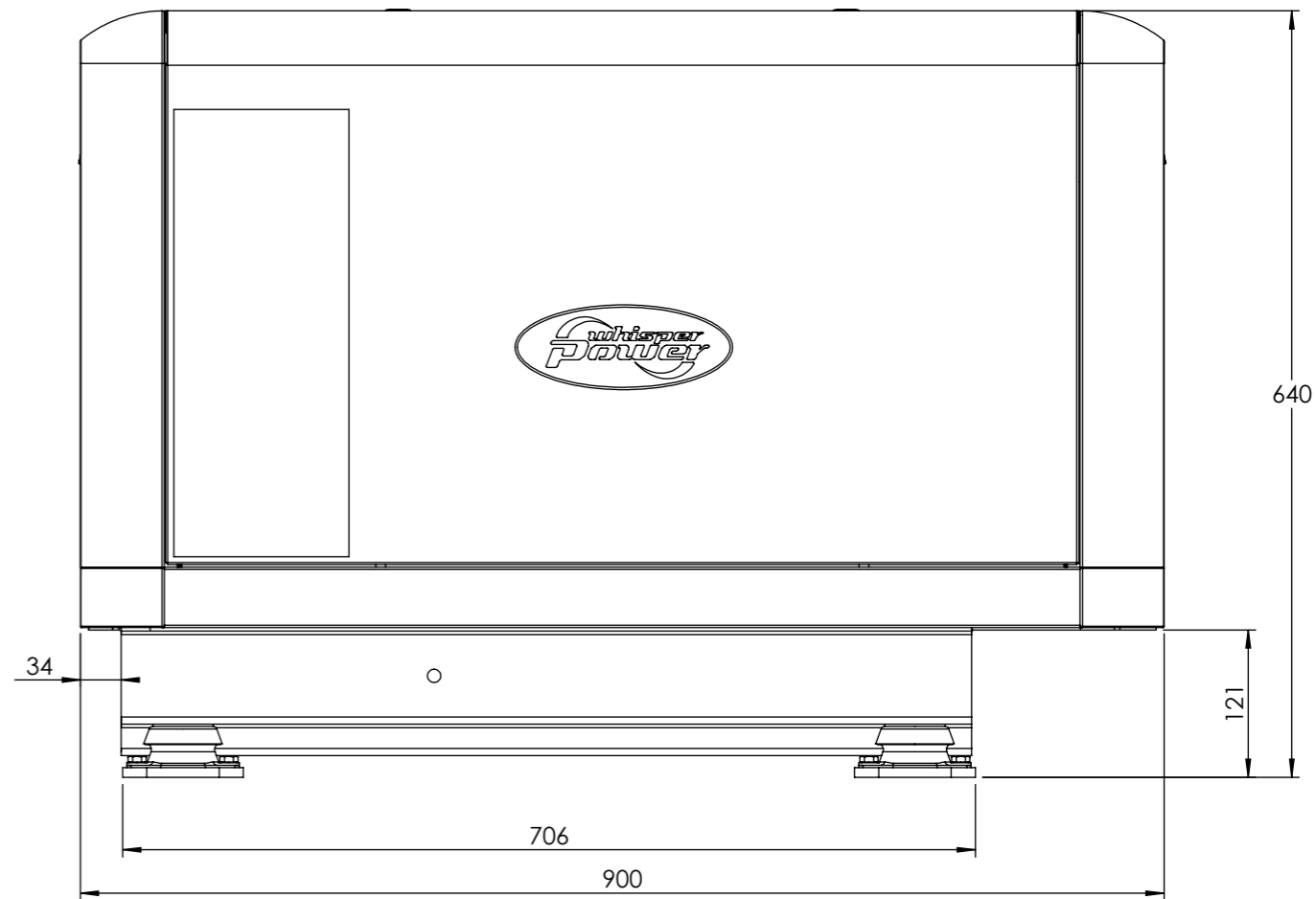

REVISIONS			
REV.	DESCRIPTION	DATE	APPROVED

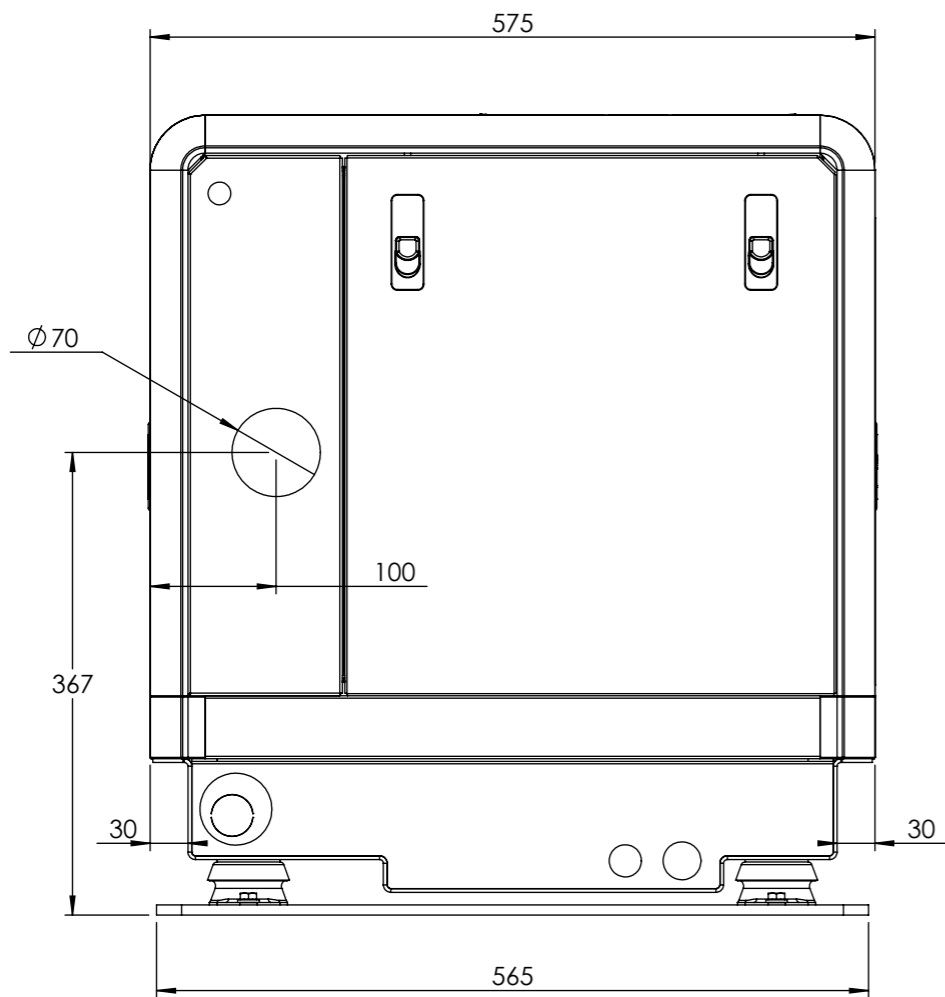
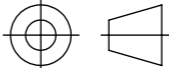

M-SQ 8  
M-SQ 10

UNLESS OTHERWISE SPECIFIED: CHAMFER SHARP EDGES GENERAL TOLERANCE NEN ISO 2768-m FORM AND PLACE TOLERANCES NEN-ISO 1101 WELDING SYMBOL NEN ISO 25 ROUGHNESS ACC. to NEN3634	TOLERANCE PRINCIPLE ISO 8015  PROJECTION : THIRD ANGLE UNITS : mm 	FINISH:	DO NOT SCALE DRAWING																								
			SHEET FORMAT: A3  TITLE:																								
<table border="1"> <thead> <tr> <th></th> <th>NAME</th> <th>SIGNATURE</th> <th>DATE</th> <th>STATUS:</th> </tr> </thead> <tbody> <tr> <td>DRAWN</td> <td>M.B.</td> <td></td> <td>11-7-2005</td> <td></td> </tr> <tr> <td>CHK'D</td> <td></td> <td></td> <td></td> <td></td> </tr> <tr> <td>APPV'D</td> <td></td> <td></td> <td></td> <td></td> </tr> <tr> <td>PRINTED</td> <td></td> <td></td> <td>12-8-2010</td> <td></td> </tr> </tbody> </table>		NAME	SIGNATURE	DATE	STATUS:	DRAWN	M.B.		11-7-2005		CHK'D					APPV'D					PRINTED			12-8-2010		DWG NO. <b>Mainassy 8U</b>	REVISION
	NAME	SIGNATURE	DATE	STATUS:																							
DRAWN	M.B.		11-7-2005																								
CHK'D																											
APPV'D																											
PRINTED			12-8-2010																								
WEIGHT:	SCALE:1:10	SHEET 1 OF 1																									