



INSTALLATION MANUAL FOR MOBILE APPLICATIONS

# W-SQ 6 / 8 / 12 / 16

- 1500 RPM -

Mobile diesel generating set 230V / 50Hz  
Digital Diesel Control



Art.nr. 40200241

WHISPER POWER BV  
Kelvinlaan 82  
9207 JB Drachten  
Nederland  
Tel.: +31-512-571550  
Fax.: +31-512-571599  
[www.whisperpower.eu](http://www.whisperpower.eu)

V1 November 2008

## TABLE OF CONTENTS:

<b>1</b>	<b>INTRODUCTION</b> .....	<b>3</b>
1.1	General .....	3
1.2	Generating sets for vehicles .....	3
1.2.1	Marine and mobile generators .....	3
1.2.2	Why two radiators: .....	4
1.2.3	Why the alternator should be cooled by water .....	4
<b>2</b>	<b>INSTALLATION</b> .....	<b>5</b>
2.1	General .....	5
2.2	Location .....	5
2.3	Instructions for optimal sound and vibration insulation .....	6
2.3.1	Further recommendations .....	6
2.4	Ventilation .....	6
2.4.1	General .....	6
2.4.2	Air strainer element .....	7
2.5	Connections .....	7
2.5.1	Fuel supply .....	12
2.5.2	Radiator cooling .....	14
2.5.3	Dry exhaust system .....	18
2.5.4	Electrical installation (12 Volt) .....	20
2.5.5	AC power system (230 Volt) .....	23
<b>3</b>	<b>INSTALLATION SPECIFICATIONS</b> .....	<b>24</b>
3.1	General .....	24
3.2	Commission table .....	24
3.3	Technical data .....	25
3.4	Installation materials .....	26
<b>4</b>	<b>DIAGRAMS &amp; DRAWINGS</b> .....	<b>33</b>
4.1	Layout generator control for W-SQ6, 8 and 12 with 230VAC fan .....	33
4.2	Layout generator control for W-SQ6 with 12VDC fan .....	34
4.3	Layout generator control for W-SQ6 with 24VDC fan .....	35
4.4	Layout generator control for W-SQ16 with 230VAC fan .....	36
4.5	Wiring colours W-SQ6, 8 and 12 .....	37
4.6	Wiring colours W-SQ16 .....	38
4.7	AC wiring diagram 230V / 50Hz .....	39
4.8	Electrical diagram radiator fan control 230VAC .....	40
4.9	Electrical diagram radiator fan control 12 / 24 VDC .....	41
4.10	Wiring diagram electronic governor (Standard for W-SQ6, 8 and 12) .....	42
4.11	Remote control panel drawings .....	43
4.12	Dimensions W-SQ6 .....	44
4.13	Dimensions W-SQ8 .....	45
4.14	Dimensions W-SQ12 .....	46
4.15	Dimensions W-SQ16 .....	47

# 1 INTRODUCTION

## 1.1 GENERAL

This installation manual applies to the installation of Whisper gensets in vehicles. This manual is valid for the following models:

Part number	Description
41105020	W-SQ6 230V 1500rpm Mobile
41105026	W-SQ6 230V 1500rpm Mobile- ungrounded
41106020	W-SQ8 230V 1500rpm Mobile
41106026	W-SQ8 230V 1500rpm Mobile - ungrounded
41107020	W-SQ12 230V 1500rpm Mobile
41107026	W-SQ12 230V 1500rpm Mobile- ungrounded
41108020	W-SQ16 230V 1500rpm Mobile
41108026	W-SQ16 230V 1500rpm Mobile- ungrounded

For other models see our website: [www.whisperpower.eu](http://www.whisperpower.eu).



### WARNING

A warning symbol draws attention to special warnings, instructions or procedures which, if not strictly observed, may result in damage or destruction of equipment, severe personal injury or loss of life.



### DANGER

This danger symbol refers to electric danger and draws attention to special warnings, instructions or procedures which, if not strictly observed, may result in electrical shock which will result in severe personal injury or loss of life.



### WARNING!

Before working (installation) on the system read the section safety instructions in the user's manual

## 1.2 GENERATING SETS FOR VEHICLES

### 1.2.1 Marine and mobile generators

Whisper Generators originate from the marine sector. But there are also specially designed Whispers available for mobile applications, suitable for supplying power on board of vehicles to use professional apparatus and equipment, strong lightning and air conditioning etc. The cooling system and exhaust system on vehicles is completely different from standard marine systems.

On vehicles the engine and alternator are individually cooled by radiator with an electric (12V/24V or 230V) driven fan. The radiators can be fitted below, on top or in the side of the vehicle.

The exhaust is of the dry type and includes a stainless flexible bellow and high quality mufflers.



Never use rubber exhaust hose, nor plastic exhaust parts in a dry exhaust system as applied on vehicles.

Unless indicated otherwise.

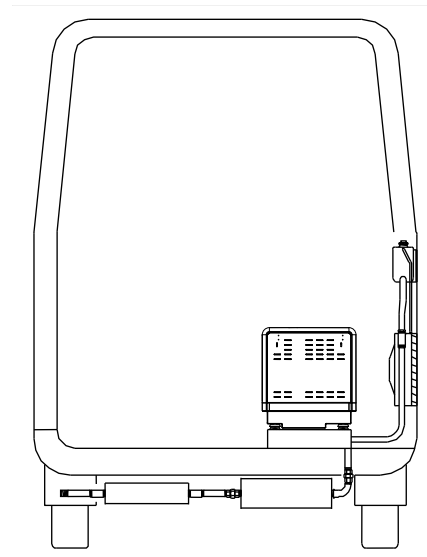

Figure 1: Typical vehicle application radiator side mounted

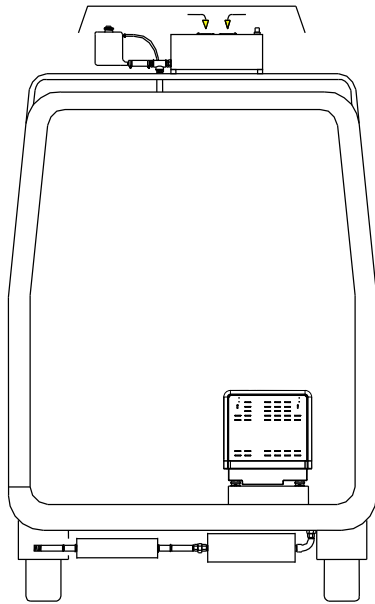

Figure 2: Typical vehicle application radiator top mounted

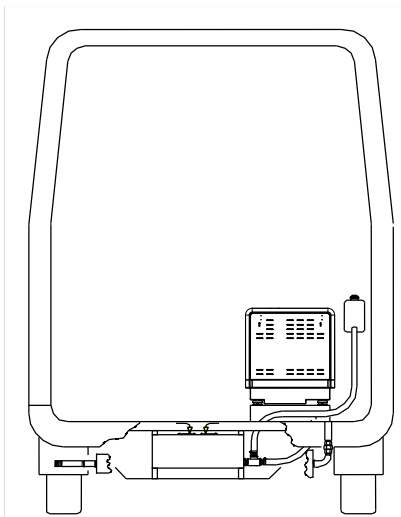

Figure 3: Typical vehicle application radiator bottom mounted

### 1.2.2 Why two radiators:

The optimum engine operating temperature is between 87° and 92° Celsius. The radiator reduces the temperature of the cooling liquid by only 5°C to 12°C. The returning “cold” coolant therefore has a minimum temperature of approx. 75° Celsius.

The alternator should be kept as cool as possible. In practice an alternator starts getting less efficient above 40° Celsius. It is hardly possible to cool down the coolant of the alternator below 40° by using a radiator. When a vehicle is in the sun on a parking place the ambient temperature itself could be 40° Celsius.

Because of the divergence in the working temperature of engine and alternator it will be clear that it is not possible to combine the cooling of the engine and alternator in one radiator system.

Furthermore it will be clear that it is very difficult to cool an alternator optimally with the aid of a radiator in conditions with high ambient temperatures.

### 1.2.3 Why the alternator should be cooled by water

For normal industrial use alternators are cooled by air. This requires a flow of air through the alternator of many m3 per minute. With the air, the noise comes out into the open. Generators on vehicles can only be made silent by full enclosure in a sound shield canopy. The only opening in the Whisper canopy is the inlet for combustion air. For that reason the alternator is cooled by water. Although cooling the alternator by circulating water through a radiator is not ideal; it is much better than by air. Therefore aircooled alternators are rarely used in vehicles.

## 2 INSTALLATION

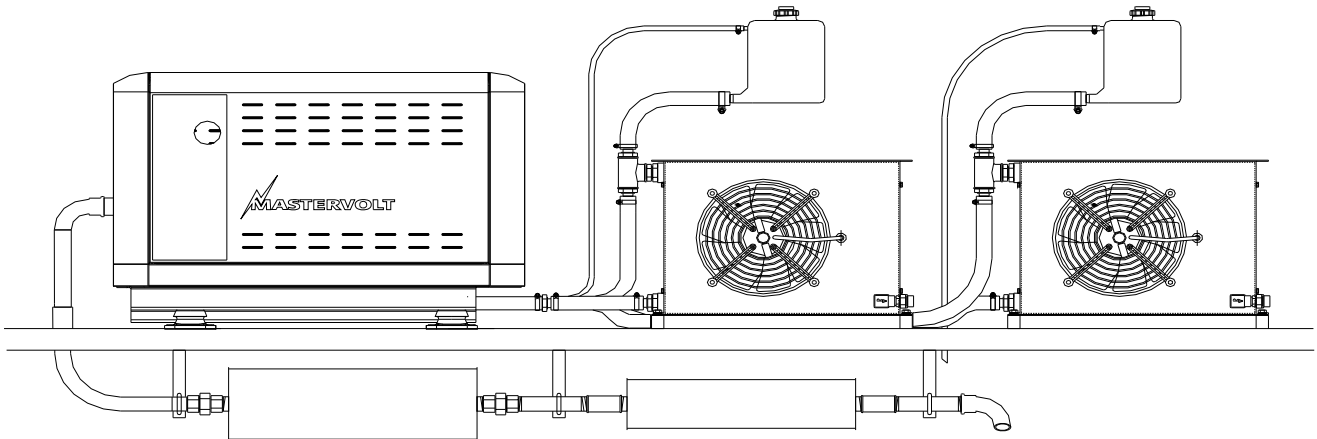

Figure 4: Schematic installation diagram

### 2.1 GENERAL

To ensure reliability and durability of the equipment, it is very important that the installation is carried out with the utmost care and attention. To avoid problems, such as temperature problems, noise levels, vibration, etc. the instructions set out in this manual must be followed and all installation work must be carried out professionally.

### 2.2 LOCATION

When looking for a proper place for a generator in a vehicle all relevant aspects have to be taken into account

- Accessibility
- Solid foundation
- Space to mount the radiators (Refer to par. 2.5.2)
- Space to mount the exhaust (Refer to par. 2.5.3)
- A way to fit the fuel lines

Since Whisper generating sets have extremely compact dimensions, they can be installed in tight locations. Please consider that even almost maintenance-free machinery must still remain accessible.

When selecting the location area in which to mount the generating set, make sure there is sufficient room to carry out any maintenance work. The unit must be easily accessible on the service side and on the distribution side to have access to the V-belt.

All models can be serviced from one side. Oil filling can be done on the service side and on the top (except for W-SQ16 that has the oil filler cap only on top). Cooling liquid can be filled via the expansion tanks.

The top of the engine (rocker cover) has to be accessible for adjustment of the valve clearance.

Please also note that in spite of the automatic oil pressure sensor it is still essential that the oil level is checked regularly.

## 2.3 INSTRUCTIONS FOR OPTIMAL SOUND AND VIBRATION INSULATION

Position the generating set as low as possible in the vehicle. The generating set is secured to the base frame by means of flexible engine mountings. This frame is mounted in the vehicle with additional vibration dampers. When it is possible to mount the unit directly on the chassis of the vehicle this has advantages in preventing vibrations by resonance.

### 2.3.1 Further recommendations

Whisper generating sets are standard equipped with a sound cover. This sound cover has been designed to give effective sound insulation. For optimum sound and vibration dampening, the following factors should be considered.

- 1 Most important is the structure on which the generator is placed to be stiff. Directly below the rubber mountings the structure should be supported vertically to the chassis of the vehicle.
- 2 In larger vehicles a separate and insulated space for the generator will help to damp the noise even further
- 3 Avoid mounting the generating set in close proximity to thin walls or floors that may cause resonance.
- 4 Sound dampening is extremely poor if the generating set is mounted on a light weight flimsy surface such as plywood which will only amplify vibrations. If mounting on a thinner surface cannot be avoided, this should be at least be reinforced with stiffening struts or ribbing. If possible, holes should be drilled or cut through the surface to help reduce the resonance. Covering the surrounding walls and floors with a heavy coating plus foam will certainly improve the situation.
- 5 Never connect the base of the generating set directly to walls or tanks.

## 2.4 VENTILATION

### 2.4.1 General

The generating set normally draws air from the engine compartment. Engine compartment with natural ventilation must have vent openings of adequate size and location to enable the generating set to operate without overheating. To allow an ample supply of air within the temperature limits of the generating set an opening of at least 100 cm<sup>2</sup> is required.

A "sealed" engine compartment must have a good extraction ventilator to maintain reasonable ambient temperatures. High temperature of intake air reduces engine performance and increases engine coolant temperatures. Air temperatures above 40°C reduce the engine power by 2% for each 5°C of rise. To minimise these effects the engine room temperature must not be more than 15°C above the outside ambient air temperature.

Apply a combination of ventilators, blowers and air intake ducting to meet the temperature limit. The air inlet ducts should run to the bottom of the engine compartment to clear fumes from the bilge and to circulate fresh air. Air outlets should be at the top of the engine compartment to remove the hottest air. An engine compartment blower should be used as an extraction ventilator to remove air from the engine room.

In cases where it is impossible to meet the above mentioned temperature limit by using engine compartment ventilation, connections are to be made for an air inlet directly to the generator enclosure. With these connections the generating set can be directly connected to an air duct. Air inlets should be louvered, where appropriate, to protect the engine room and to protect the generating set from rain and water spray.

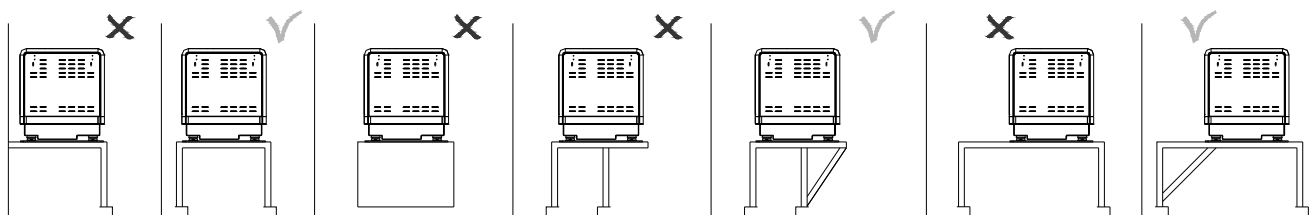

Figure 5: Mounting of the Whisper generating set. X = wrong, V = OK

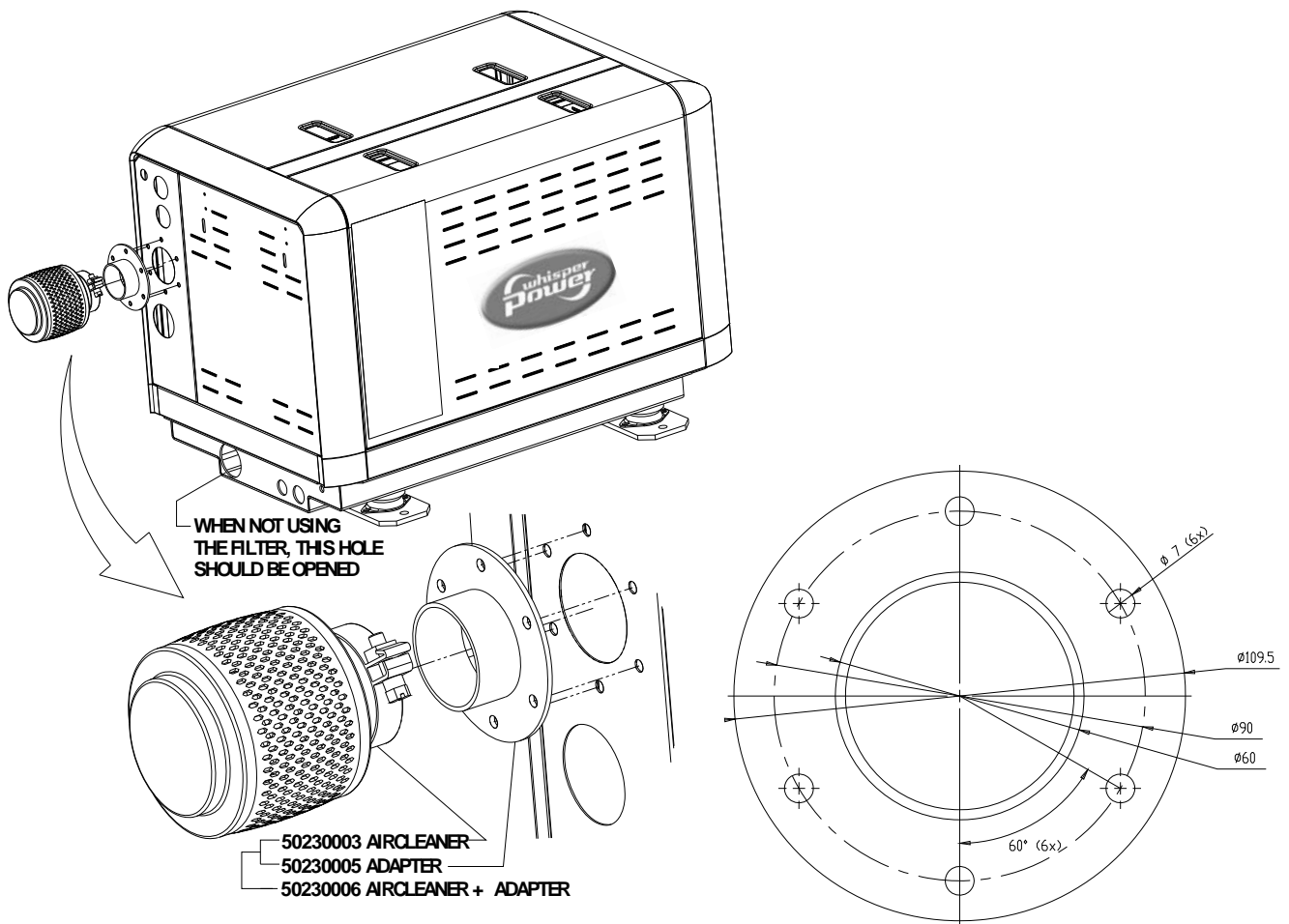

Figure 6: Mounting of the air strainer element

### 2.4.2 Air strainer element

Applying a generator in a vehicle, where combustion air is taken in from below the vehicle, there is often much dust, sand and dirt in the air. For these applications Whisper Power prescribes the installation of an air strainer element. This air strainer element is in the standard supply, but not yet mounted as often the best place to mount it will be different in any installation.

To install the air strainer element one has to find the best place somewhere on the canopy. Figure 6 shows the recommended place, but the filter can be mounted everywhere, even on the bottom, hanging down.

Use sealant or kit between the flange and the surface.



**ATTENTION!**  
In any case it is necessary to open a hole for air inlet!



**ATTENTION!**  
Before working (installation) on the system read the section safety instructions

### 2.5 CONNECTIONS

The generating set comes with all supply lines and output cables (i.e. electric cables, coolant connections, exhaust, fuel lines etc.) already connected to the engine and generator. The supply lines are fed through the capsule's front base. The connections are marked as shown in figures 7 till 10.

All electrical connections, cable types and sizes must comply with the appropriate national regulations. Supplied cables are rated for ambient temperatures up to 70°C. If the cables are required to meet higher temperature requirements, they must be run through conduits.

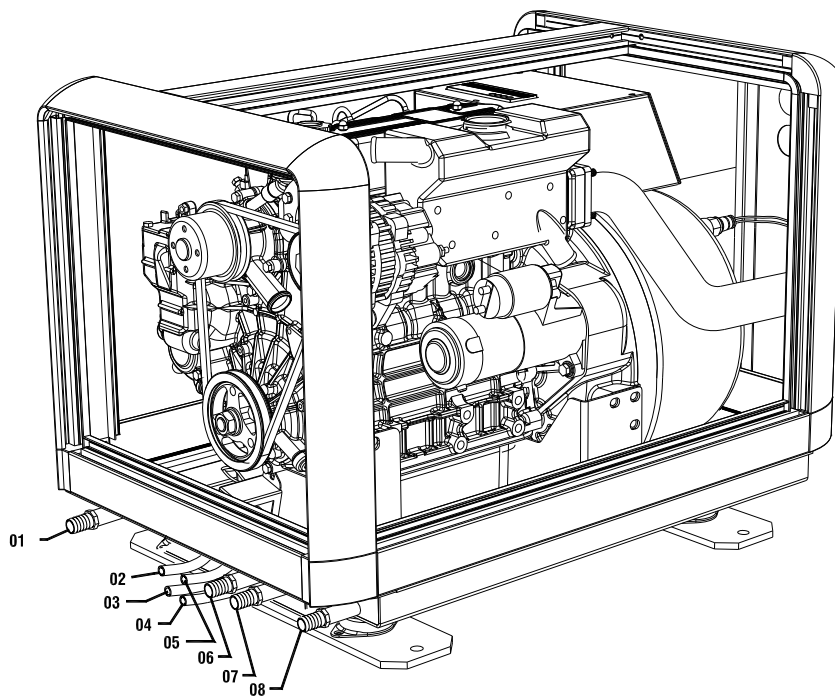

- 01 Coolant generator in
- 02 Battery positive (+)
- 03 Fuel out Ø8mm
- 04 Fuel in Ø8mm
- 05 Battery negative (-)
- 06 Coolant engine out
- 07 Coolant engine in
- 08 Coolant generator out

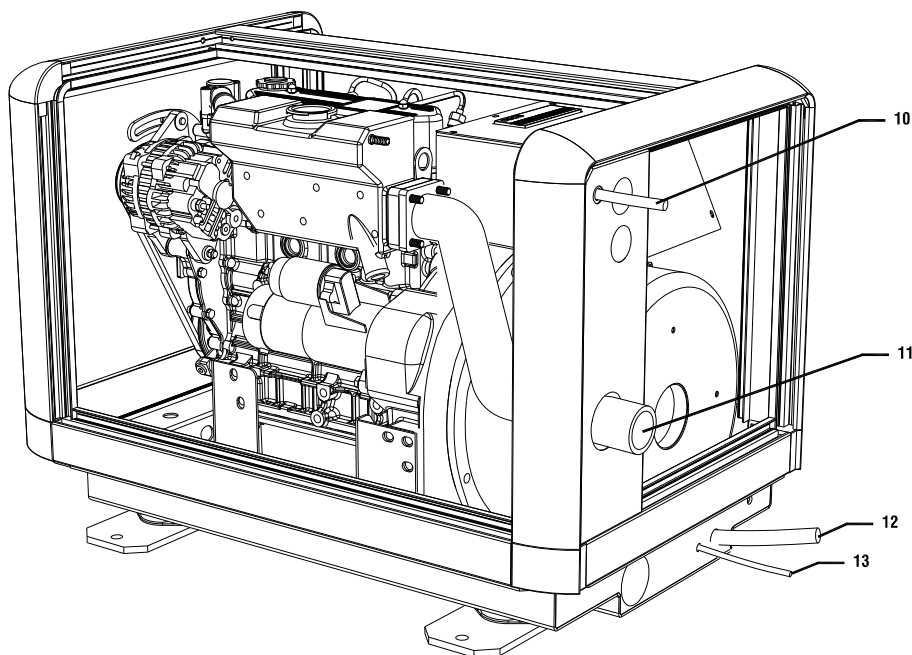

- 10 Expansion tank
- 11 Exhaust 1½"
- 12 AC power output
- 13 Remote control

Fig. 7 Connections W-SQ6 for mobile application



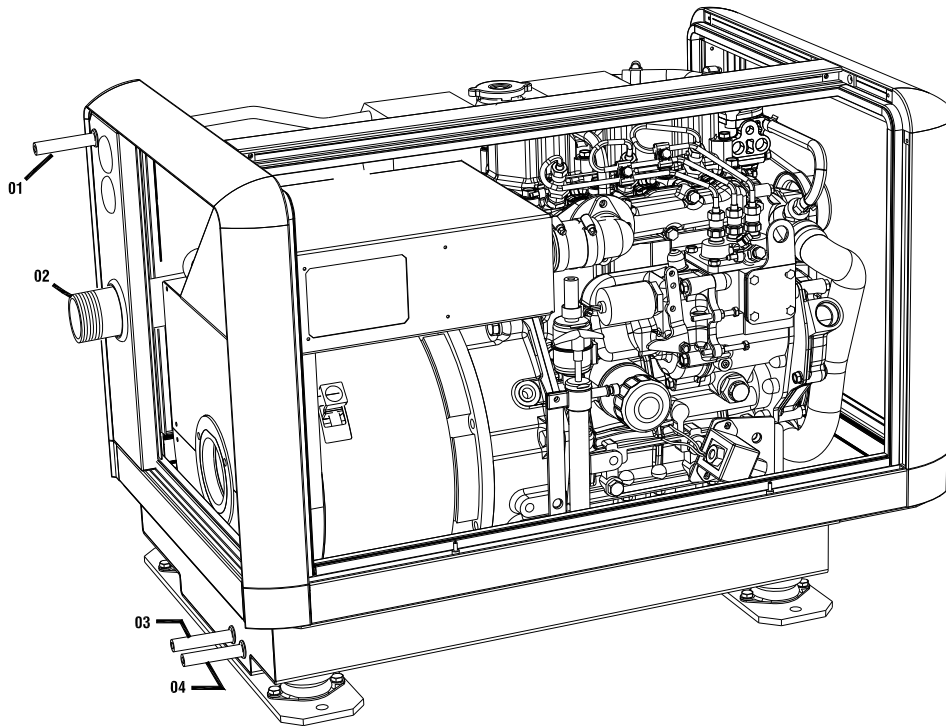

- 01 Expansion tank Ø8mm
- 02 Exhaust 1½"
- 03 Remote control
- 04 AC power output

Fig. 8a Connections W-SQ8

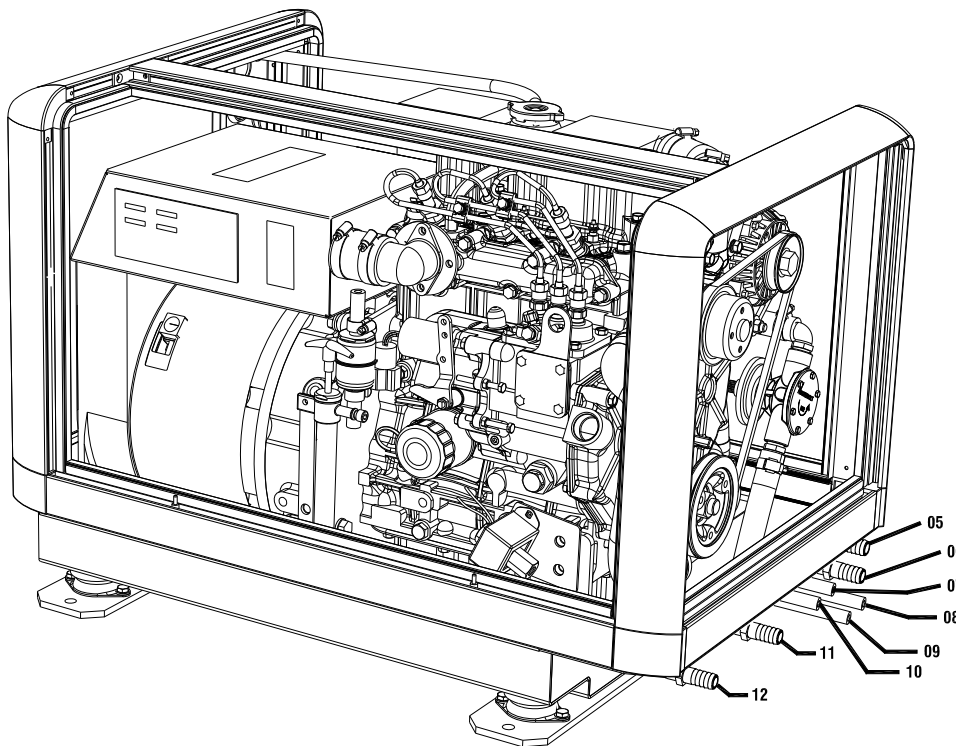

- 05 Coolant engine out
- 06 Coolant generator out
- 07 Battery negative (-)  
25mm<sup>2</sup>
- 08 Fuel out Ø8mm
- 09 Fuel in Ø8mm
- 10 Battery positive (+)  
25mm<sup>2</sup>
- 11 Coolant generator in
- 12 Coolant engine in

Fig. 8b Connections W-SQ8

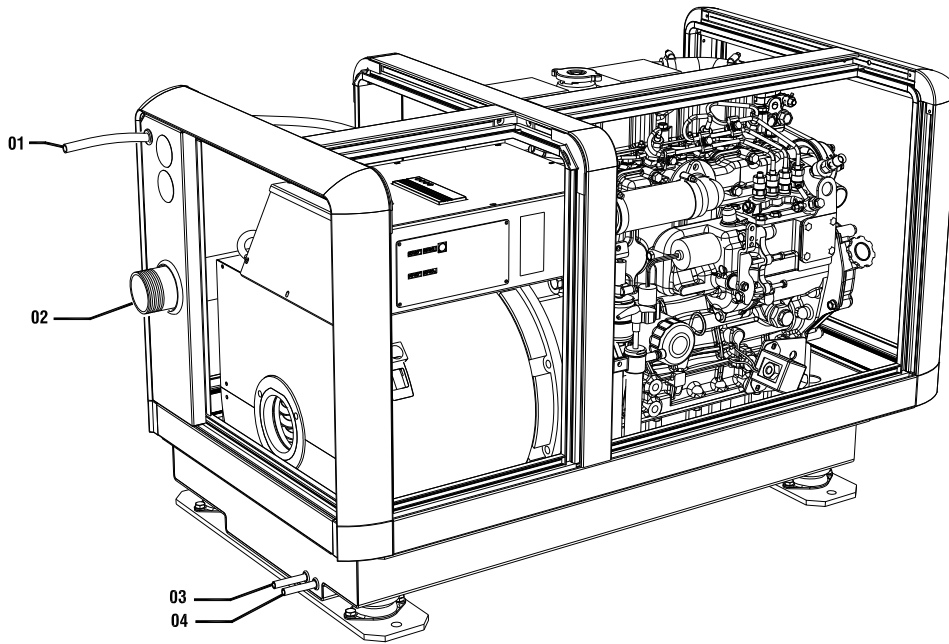

- 01 Expansion tank Ø8mm
- 02 Exhaust 1½"
- 03 Remote control
- 04 AC power output

Fig. 9a Connections W-SQ12

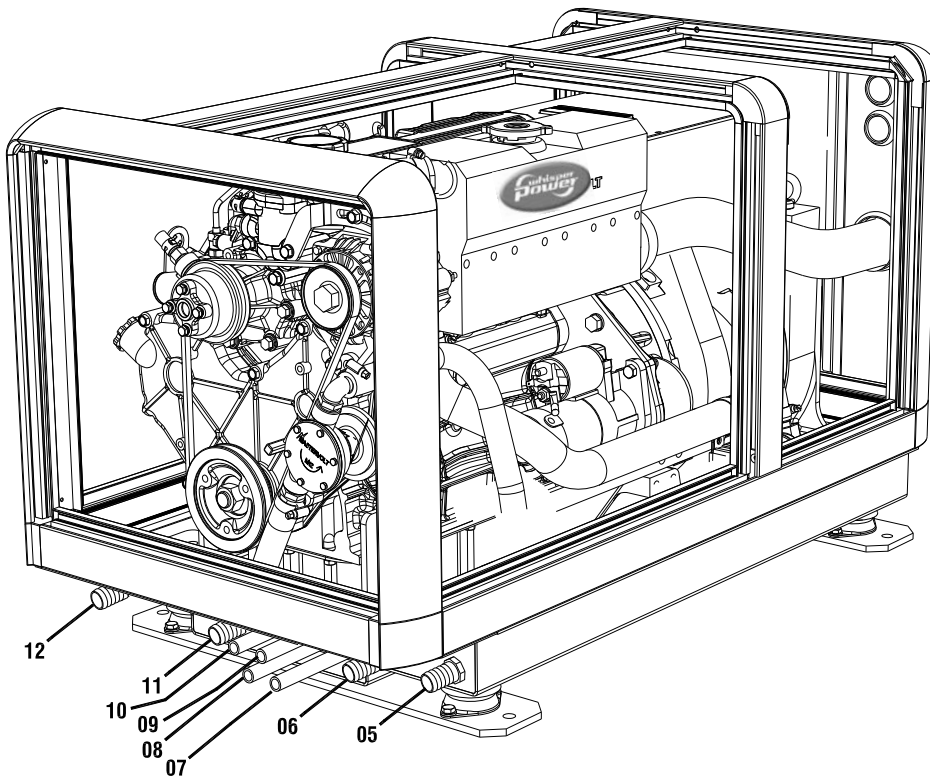

- 05 Coolant engine out
- 06 Coolant generator out
- 07 Fuel out Ø8mm
- 08 Fuel in Ø8mm
- 09 Battery negative (-)  
25mm<sup>2</sup>
- 10 Battery positive (+)  
25mm<sup>2</sup>
- 11 Coolant generator in
- 12 Coolant engine in

Fig. 9b Connections W-SQ12

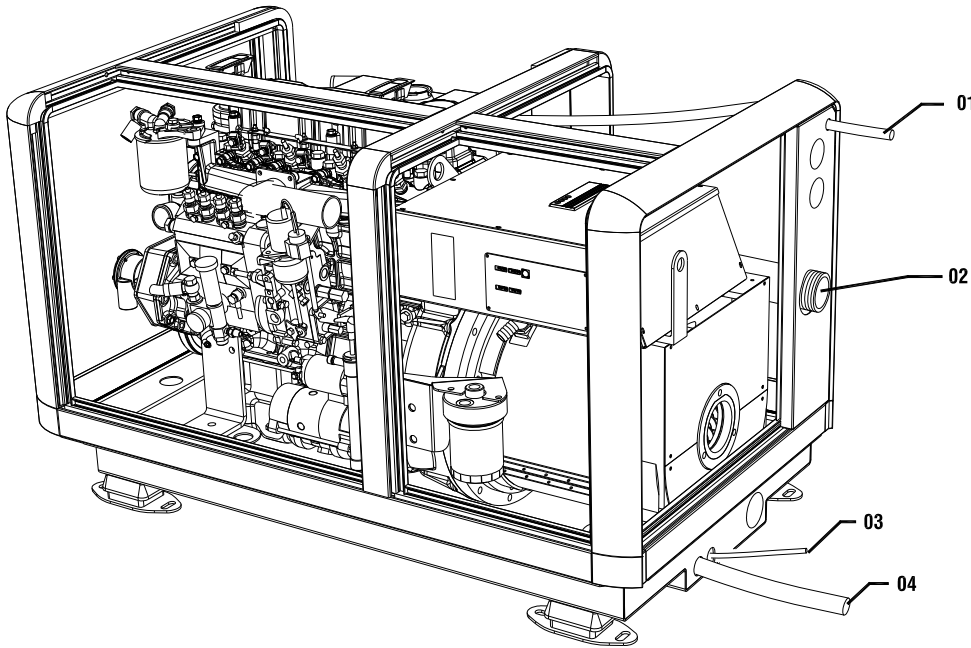

- 01 Expansion tank Ø8mm
- 02 Exhaust 1½"
- 03 Remote control
- 04 AC power output

Fig. 10a Connections W-SQ16

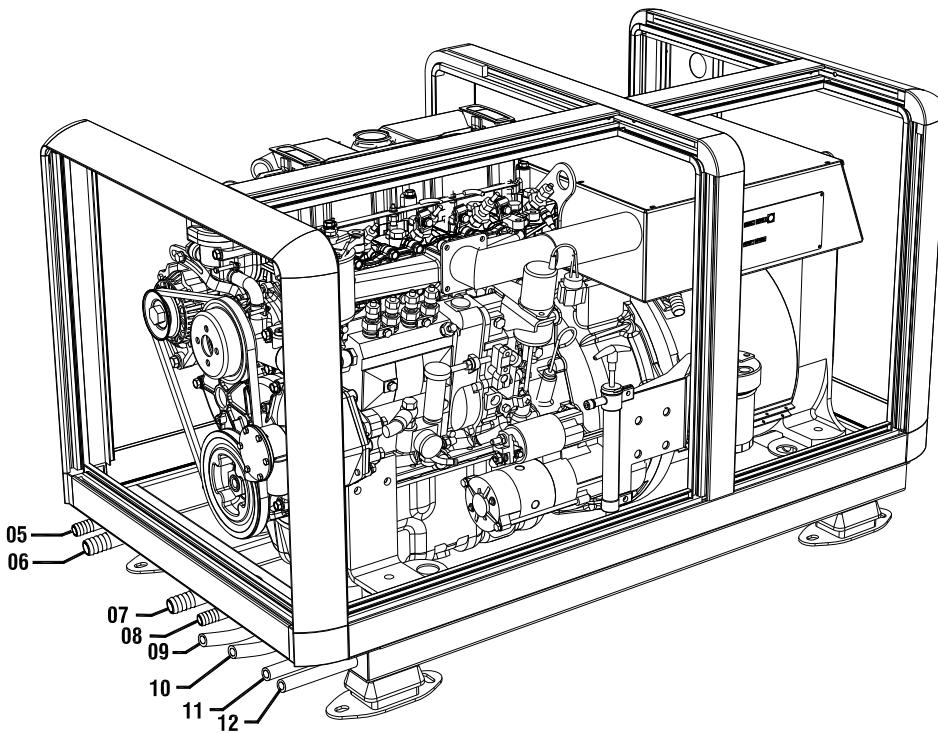

- 05 Coolant engine out
- 06 Coolant generator out
- 07 Coolant generator in
- 08 Coolant engine in
- 09 Fuel in Ø8mm
- 10 Fuel out Ø8mm
- 11 Battery positive (+)  
35mm<sup>2</sup>
- 12 Battery negative (-)  
35mm<sup>2</sup>

Fig. 10b Connections W-SQ16

## 2.5.1 Fuel supply

### 1 FUEL TANK

Fuel tanks should be made of appropriate material such as (stainless) steel or plastic. Steel tanks should not be galvanised or painted inside. Condensation can occur in metal tanks when temperature changes. Therefore, water accumulates at the bottom of the tank and provisions should be made for the drainage of this water.

The tank will need a filling connection, a return connection and an air ventilation connection which will require protection against water entry.

Some official regulations do not allow connection points at the base of the fuel tank; connections are to be made at the top of the tank with internal tubing down to a few cm above the bottom of the tank. Using the existing fuel tank of the car-engine the fitting should be carried out with extra care. Both a supply line and a return line should be installed and go into the tank from the top. Interference of the two systems (car engine and generator engine) should be avoided.



Do NOT connect the fuel lines to the lines of the vehicles engine fuel supply.



Driving the tank empty below the level of the suction pipe of the generator could make it necessary to bleed the fuel system.

### 2 FUEL LIFT PUMP

The generating set itself is equipped with a fuel lift pump; therefore the tank can be installed at a lower level than the generating set. See figure 12. The maximum suction height is 1 m. The W-SQ16 has a mechanical fuel lift pump that should be primed manually when the first time used.

If the pump has to lift the fuel higher than one meter an external fuel lift pump must be installed (Art. No. 50201060). The control board is already prepared to connect an extra fuel pump. When using a second electric fuel supply pump, it is recommended to mount a loose supplied pump close to the tank and mount it in an angle or vertical to prevent air bubbles to block the system. The pump will become quite hot and should be mounted out of touch. (Refer to fig. 13) The pump makes clicking noises and therefore could be mounted on rubber mountings. When the clicking noises of the pump are not acceptable another noiseless pump is available as an option (Art. No. 50202200).

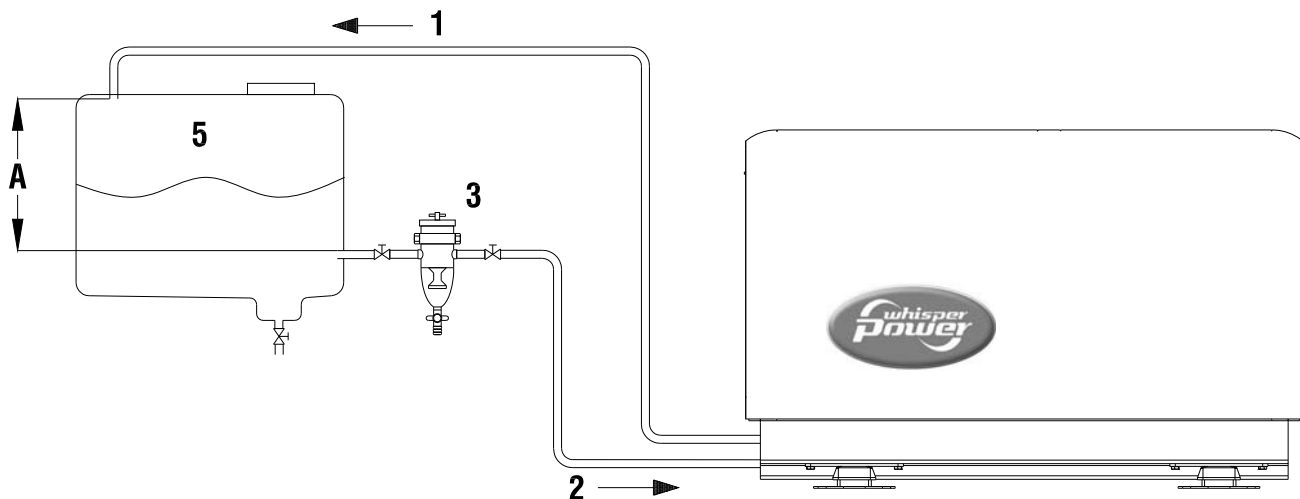

Fig. 11 Fuel supply (fuel tank is above the generating set)

- 1 Fuel return
- 2 Fuel supply
- 3 Prefilter / Water separator (optional)
- 5 Fuel Tank

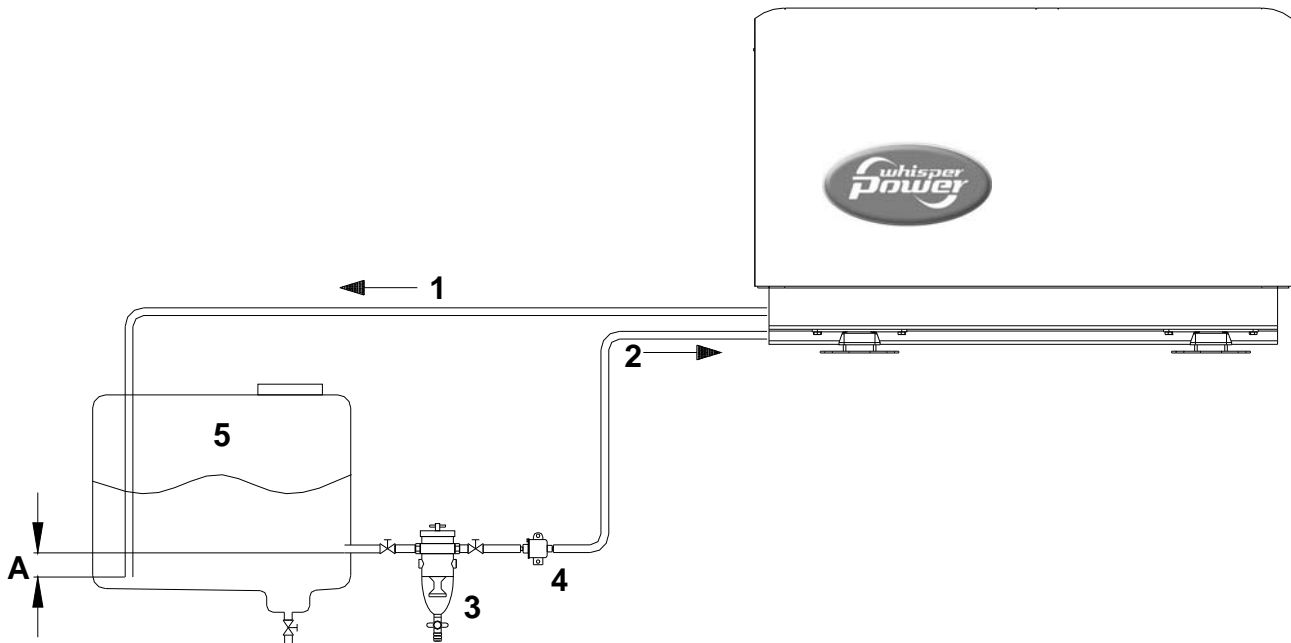

Fig. 12 Fuel supply (fuel tank is below the generating set)

- 1 Fuel return
- 2 Fuel supply
- 3 Prefilter / Water separator (optional)
- 4 Extra fuel lift pump (optional)
- 5 Fuel tank

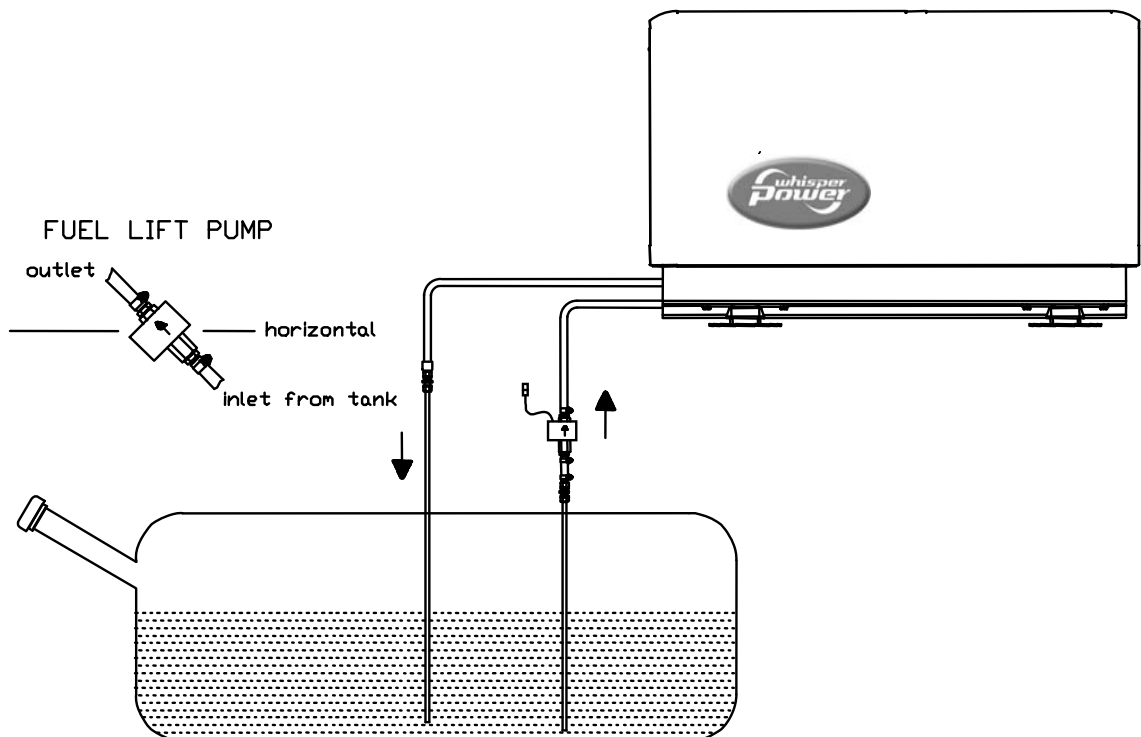

Figure 13: Fuel line assembly with vertical mounted pump and fuel lift pump mounted in an angle

### 3 FUEL PIPES

When the tank is above the generating set (figure 11) we recommend ending the return line on the top of the tank. When the return is on the top - in case of a leakage the return line cannot overflow because of siphoning. One will only need a fuel cock in the fuel supply line. When the tank is below the generating set we recommend ending the return line on the bottom of the tank (A) below the inlet of the supply line.

Both supply and return fuel pipe lines should be appropriate material and 8 mm outer diameter tubing. The quality of the tubing of fuel pipes could be submitted to local regulations depending on the application of the vehicle.

The fuel pipes can be plumbed to the flexible hoses which are on the generating set and have a connection to fit to 8 mm pipe. This fuel lines fulfils CE standards and are according to ISO 7840 A2.

It is important to avoid bends in the pipes, as they could trap air bubbles. The return pipe should never be connected to the suction pipe. The return line should be of 8 mm diameter and go straight back via the top to the bottom of the tank. When the return is too narrow, has too many bends and goes back to the bottom of the fuel tank, the back-pressure could be too high. This results in irregular running of the engine. When the engine runs irregular, one can check if back-pressure is the problem by disconnecting the return line just outside the canopy and draining it in a canister. When the engine runs smooth now, the return piping has to be changed. It could also help to install a second (electrical 12V) fuel lift pump in the supply line to increase the pressure.

### 4 FUEL FILTERS

A fine fuel filter is installed which requires maintenance. Whisper Power advises to install an extra fuel filter/ water fuel separator near the fuel tank.

Before starting your generating set for the first time follow the fuel system bleeding procedure in the users manual.

### 2.5.2 Radiator cooling

#### 1 GENERAL INSTRUCTIONS

The radiators can be mounted below the floor, in the side or on the roof of the vehicle. Wherever the radiators are mounted the well functioning of the system depends on the well circulation of the coolant. Roof mounted radiators bring the most risk for circulation problems, because air trapped in the radiators or a low level of the coolant, will immediately affect the cooling capacity of the radiators. It is recommended to keep the radiators as close as possible to the unit. The piping should be fitted as direct as possible.

When the radiators are above the engine, the piping should be fitted below the top of the radiators! (refer to figure 14). Bents in the piping, that can trap air bubbles, should be avoided or ventilated (refer to figure 15)

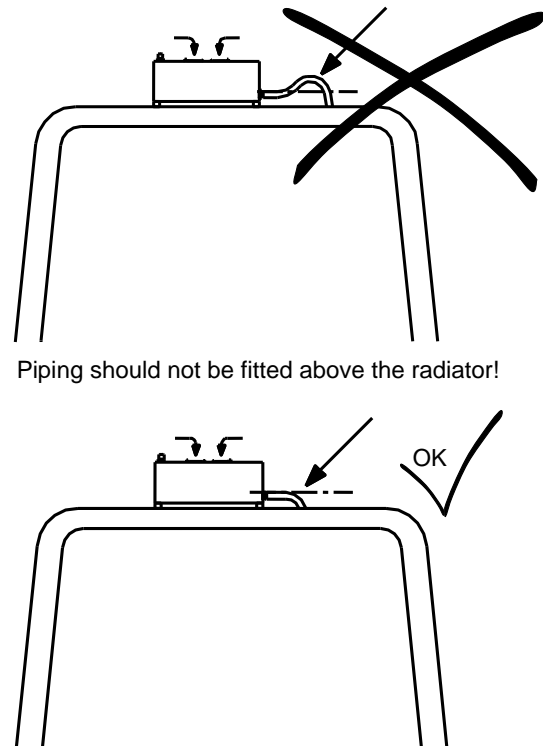

Figure 14: Air traps should be avoided

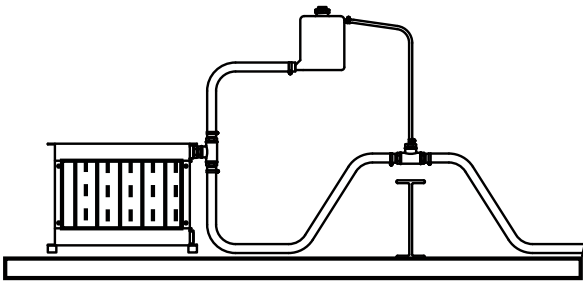

Figure 15: Ventilating an air trap

Special attention should be paid to the ventilation of the systems. Each installation system is standard supplied with an expansion tank for the coolant, which is also used to release air bubbles and makes it possible to add coolant into the system in an easy way. This expansion tank should be at the highest point of the system and mounted as high as possible.



Most cooling problems originate from air traps blocking the circulation of the engine coolant.

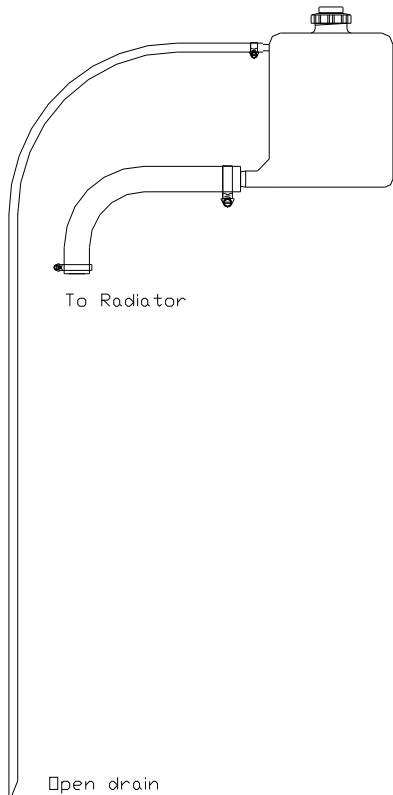

Figure 16. Alternator cooling system: open expansion tank with overflow pillar.

For the alternator cooling system we use an open -non pressurised- system. Therefore the 12 mm overflow pillar on the expansion tank should stay open (figure 16). A piece of hose can be used to drain redundant liquid that is thrown out because of the expansion of the liquid in the system. When open the expansion tank can easily release air that is ventilated by the different connections. As the capacity of the alternator cooling system is very small, also the initial filling can be done via the expansion tank. It could be necessary to refill the tank a few times. The pump of the alternator cooling system is self-priming and this makes the system less sensitive for air traps.

For the engine we use a pressurised system. The 12 mm connection on the top is closed. Wherever the radiators are mounted it is necessary to ventilate the exhaust manifold of the engine. The exhaust manifold has a 8 mm connection to ventilate the manifold. There is an 8 mm high pressure and high temperature resistant hose in the delivery to connect the hose connection on the side of the manifold with the expansion tank. (refer to figure 7 till 10).

Initially the engine cooling system can be filled via the cap on the exhaust manifold of the engine. However when the radiator is above the engine one can only fill the system to the level of the manifold. Additional filling has to be done via the expansion tank.

For large engine cooling systems with long pipes or for extra reserve there is an extra large expansion tank with a content of 7 litres and an alarm for low coolant level that can be supplied as an option (refer to figure 16).

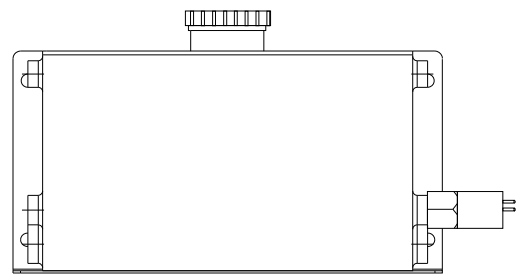

Figure 17:  
7 litres optional expansion tank with low level alarm.

When mounting the radiators it is important to take care that the outgoing connection, which is the connection to the engine inlet, is on the top position (refer to figure 18 detail A) and is connected to the expansion tank. Also when the radiator is mounted flat at the bottom of the vehicle the outgoing connection is connected to the expansion tank. This is the best way to have the system release air and to add liquid when necessary.



The expansion tank must be fitted in the outlet of the radiator = the inlet pipe of the engine

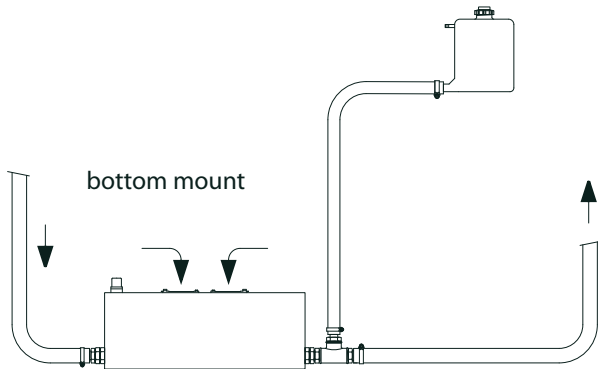
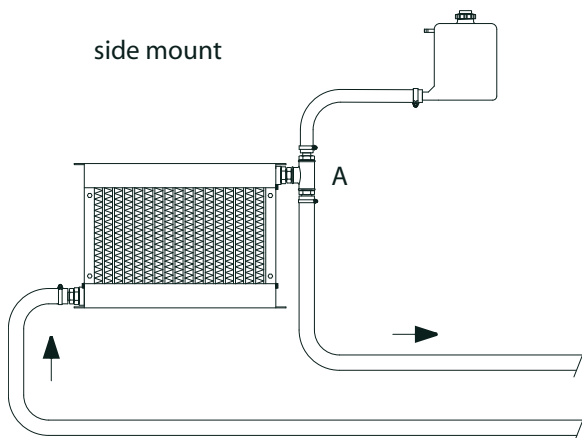

Figure 18.  
Outgoing connection connected to the expansion tank

When both radiators are flat mounted on the roof, the expansion tanks should be mounted a little higher. (refer to figure 19 detail B).

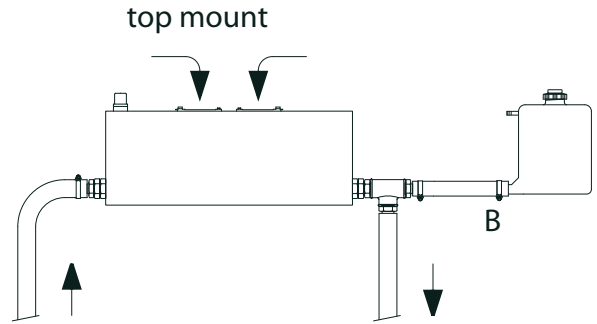

Figure 19:  
Low profile radiator assembly on the roof



Most cooling problems originate from air traps blocking the circulation of the engine coolant.



It is very important to use good quality heat resistant hose and fittings. Therefore it is strongly advised to use Whisper Power installation kits from Whisper Power.



## 2 HOW AND WHERE TO MOUNT THE RADIATORS

The radiator kit includes rubber mountings to prevent vibrations to be transferred to the body of the vehicle (fig. 20). Due to the difference between vehicles general instructions are not available. One has to find out where the best place for mounting is. For OEM customers Whisper Power can supply a special customised installation kit.

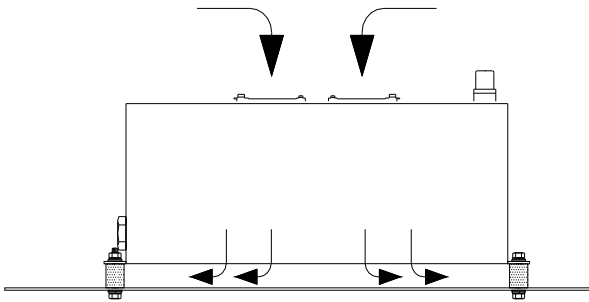

Figure 20. Radiator on rubber mountings

### Bottom mounted radiators

When bottom mounted the radiator should not be the lowest point of the vehicle to avoid damage.

A free flow of air should be guaranteed. When horizontal mounted, the fan should be on top, which causes a flow of air downwards. Often it is possible to find a place where extra space above the fan helps to create a free flow of air. It is recommended to make a shield below the radiator to catch stones and dirt and operates as a spoiler. The distance between the radiator and the shield should be at least 50 mm. Sometimes it is possible to build the radiators and shield on a sub frame that is mounted below the vehicle as a module.



Measures have to be taken to prevent the hot air circulating and reducing the capacity of the radiators. Refer to figure 21

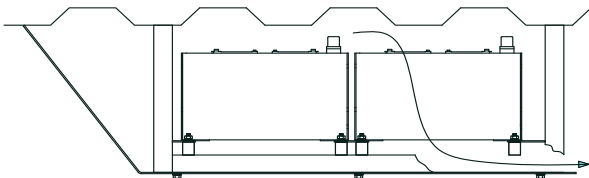

Figure 21: Bottom mounted radiators with shield

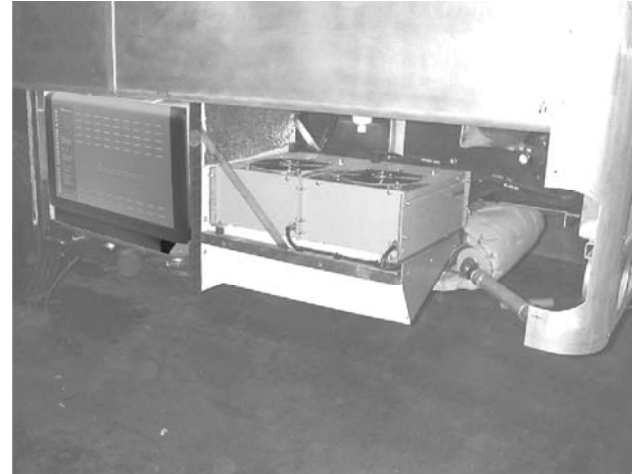

Figure 22. Making use of the space below the floor to get an optimal flow of air through the radiators.

### Side mounted radiators

Most effective and easy is to mount the radiator in the side of the vehicle, if possible below the level of the top of the engine. A louvered grid should protect the radiator from rain and objects, but must not block the airflow. The fan should be inwards which causes the air to blow outwards. A disadvantage of having the radiator in the side is possibly more noise of the electric fan and a flow of air that could be felt by people passing by.

A free flow of air should be guaranteed. The ventilation connection of the cooling system that goes to the expansion tank, should be in the outgoing coolant flow on top of the radiator.

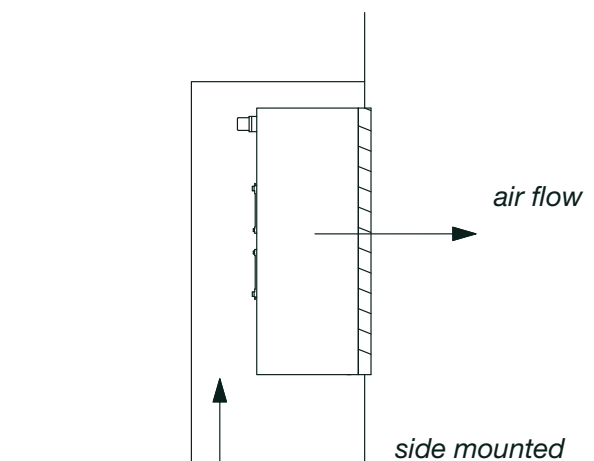

Figure 23: Side mounted radiator

### Roof mounted radiators

The radiators on the roof is often the best option from the point of view of keeping the noise of the fans away from people and it will give the best result in dissipating the heat. However, often this option conflicts with the possible need to keep the vehicle as low as possible.

Another disadvantage is that the piping has to go through the roof which requires provisions to be waterproof. Also negative is that roof mounted radiators are more sensitive for air traps (see figure 14). When having enough space it would be ideal to have the radiators vertically mounted on the roof. Note that the expansion tank should be above the radiator.

When having the radiators horizontally mounted on the roof (refer to figure 24) enough space (50 mm) should be between the roof and the radiator fan to have a free flow of air. When the radiators are roof mounted there should be protection against weather conditions. To avoid damage while the vehicle is driving at high speed, the use of a spoiler could be necessary.

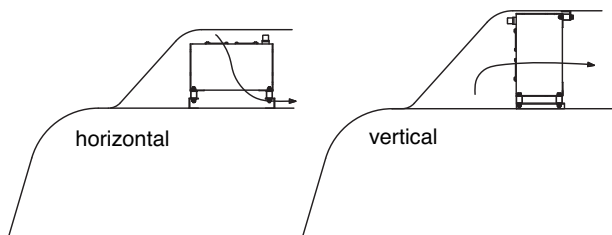

Figure 24: Two examples of top mount radiators

### 3 TWO SPEEDS FAN (OPTIONAL)

To keep the noise as low as possible the fans of the radiators can run at two different speeds. As option a control box is available which can be used to drive the fans with two speeds, depending on the load of the generator. When using 12/24V DC to drive the fans (see chapter 4.9), in normal mode the electric motors of the fans are connected in series and run at low speed. In this mode they almost produce no noise. Only when necessary - this is controlled by thermostat switches - the fans are switched in parallel and will blow at full speed.

The same is achieved with 230 V fans with help of a transformer (refer to the connection diagrams in paragraph 4.8).

However, when not strictly necessary, we recommend using the standard fan control instead of the two speeds fan control, in order to keep the system as simple as possible.

### 2.5.3 Dry exhaust system

#### 1 GENERAL REMARKS

A dry exhaust muffler system should be very effective in silencing the exhaust when applying the right mufflers. However noise could be generated by vibrations in the mufflers and be transferred to the chassis. Tacit factors like the length of specific pipe sections could cause the noise to be amplified. It is very difficult to take these factors into account.

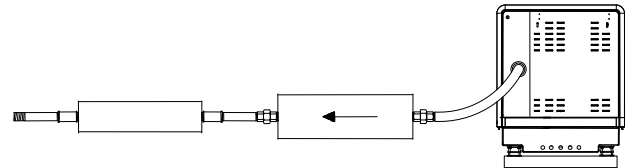

Figure 25: Dry exhaust systems on vehicles

The standard Whisper Power exhaust kit contains the materials to perform a professional installation. In the kit is a stainless steel flexible bellow (hose) to allow for expansion and to prevent vibrations to be transferred. Rubbers are supplied to mount the mufflers flexible. The insulation blanket for the flexible bellow and the resonance muffler are also very effective in damping vibrations. Still it could be that additional measures has to be taken like an extra clamp in a vibrating section of pipe, insulation blankets on other parts of the system and possibly even additional mufflers.



When the exhaust is led through the roof of a vehicle, measures has to be taken to prevent rainwater to enter the system. Special rain caps are available as an option.

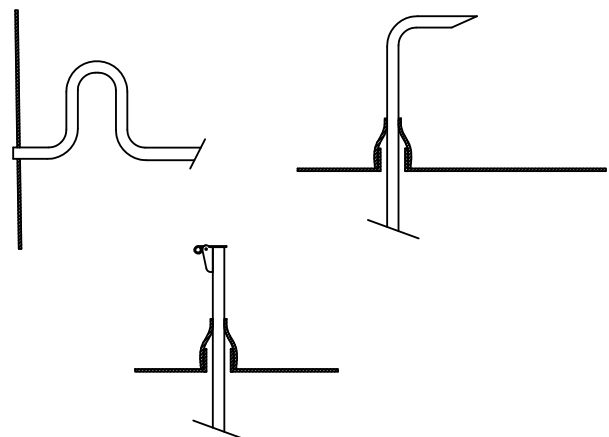

Figure 26. Ways to prevent water to get in

A negative feature of a dry exhaust system is the heat radiated by its components. Measures are taken to overcome the heat problem: The exhaust bent to bring the exhaust out of the canopy is cooled by water. Insulation blankets are included in the exhaust kit to insulate the flexible bellow and the first muffler.

When a dry exhaust has its outlet on the roof, all the pipes inside the vehicle has to be insulated.



The exhaust pipes will be very hot and all accessible pipes and mufflers are dangerous to people when not insulated.

There are companies that are specialised in insulating hot pipes and fancy systems are available to make it good looking. However it is also possible to do it yourself by winding fibreglass or Rockwool around the pipes and seal it with aluminium tape.

## 2 THE STANDARD DRY EXHAUST SYSTEM

The standard exhaust system contains:

On the generator set:

- An insulated exhaust bent

In the exhaust installation kit:

- A stainless steel shielded flexible bellow.
- One resonance muffler
- One absorption muffler
- Clamps and rubbers to mount the system flexible
- Fittings, bents and pipes to make the different connections
- Blankets for thermal and sound insulation.

The mufflers are high quality industrial mufflers that are much more effective, robust and durable than mufflers made for automotive use.

## 3 INSTALLATION OF THE EXHAUST

Before determining the location of the generator set one has to consider how to get away with the exhaust. Often one can find space below the vehicle between the chassis to mount the mufflers. The outlet should blow the fumes away from the doors to avoid a nasty smell. When the gasses are in the flow of air blowing from the radiators this will help to avoid the fumes to be noticed. Under no condition the fumes should be sucked into the flow of air into the radiators. In wind still conditions a light smell of exhaust fumes around the vehicle will not be avoidable.

To bring the exhaust to the top of the vehicle gives the best results on noise and smell. However, when the pipes go through the vehicle they should be insulated and around the hole in the roof should be a collar to prevent rainwater to leak in. Both mufflers could be on the roof or one of them or both could be below the vehicle.

In general it is better to have the mufflers wide apart: the resonance muffler close to the generator and the absorption muffler on the end of the line. A short pipe (30cm) should be on the far end after the absorption muffler. The absorption muffler has no flow direction and could be mounted both ways. The resonance muffler should be mounted according to the indication on the muffler itself.



The resonance muffler should be fitted according to direction of the gas flow indicated.

In the kit are clamps to mount the exhaust pipes to stainless steel bars. These bars should be mounted to the chassis of the vehicle. It is recommend to use rubber mountings whenever possible. However take care that the heat conducted through the brackets will not affect the rubber. Refer to figure 19 how to mount the rubber in a safe way. When any doubt an extra safe guard could be constructed from steel wire or chain.

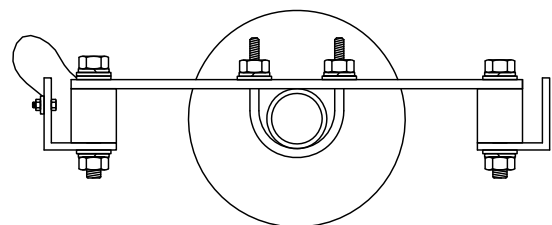

Figure 27. Mounting bracket in rubber with safe guard

## 2.5.4 Electrical installation (12 Volt)

### 1 DIGITAL DIESEL CONTROL SYSTEM

The electrical control system is standard in 12 Volt with negative earth. Non- earth return is available as an option.

All electrical wiring has been prepared on the generating set to the control panel prior to despatch from the factory. The engine is controlled by a very advanced microprocessor based system: Digital Diesel Control. The "black box" containing the microprocessor is located on top of the alternator.

A local control panel is on the generating set.

#### Remote control

A remote control panel also containing a microprocessor is in the delivery. A 15 m intermediate 8-pole communication cable is in the standard supply as well (refer to fig. 28). If necessary an optional longer (up to 30m / 100ft) intermediate cable can be connected if the standard length does not suit the required distance. When a longer distance than 30m / 100ft is required, consult the Whisper Power service department for advice.

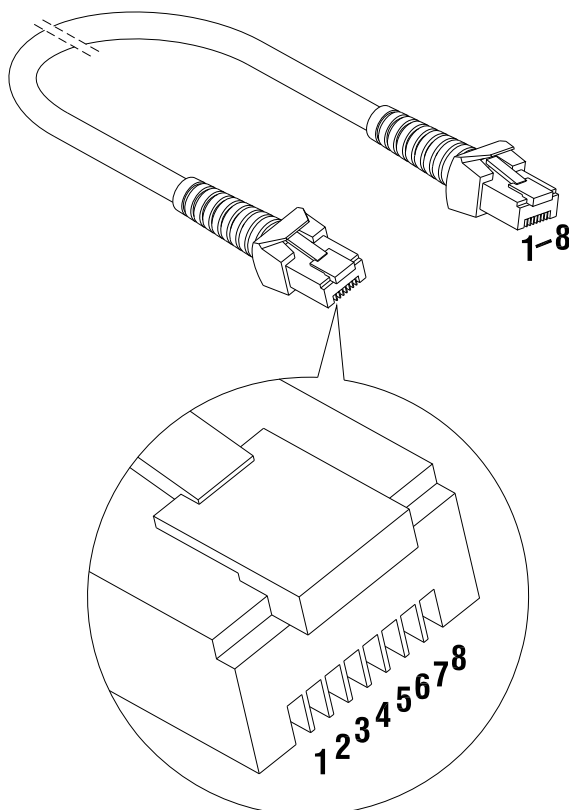

Fig. 28 Remote control cable

One can mount the control panel after drilling a hole in the dashboard using the plastic cover. Refer to the dimensional drawings in chapter 4. The panel without the plastic cover fits the Mastervision modular panel system.

More remote control panels (slave panels) can be put in parallel by using the modular connectors on the back of the units. As a slave one can use the same panel offering all functions again. It is also possible to use an old or new type slave panel only to start and stop the generator. Old type remote panels and system panels can be connected by means of the green connector.

When using the factory settings, installation is very simple: just plug the remote cable into the remote and the generator is ready to use. Refer to fig. 29.

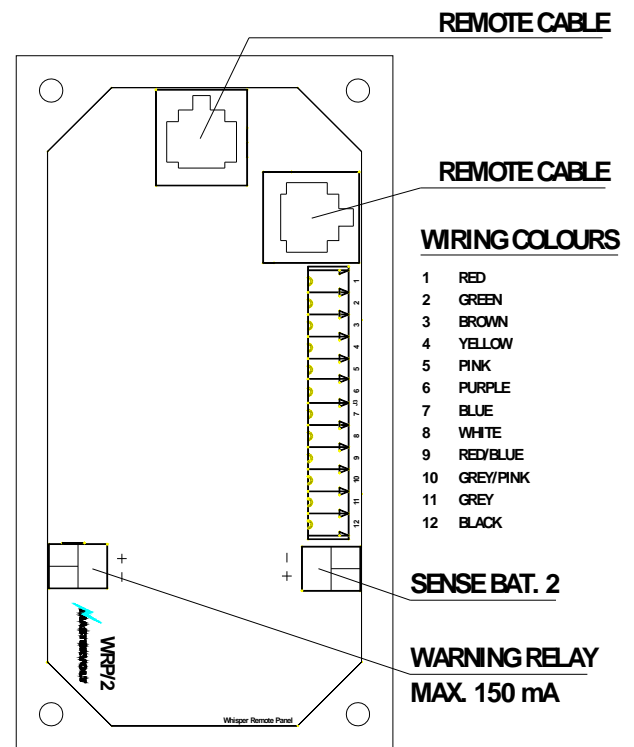

Fig. 29 Remote box terminals

#### Acoustic alarm or warning lamp

One can connect an external max.150 mA relay to generate an acoustic warning or applying a warning lamp etc. Be aware of polarity as some relays has a diode inside and should be connected plus to plus en minus to minus as indicated. Refer to fig. 29.

#### Connection for emergency stop / fire alarm switch

To connect an emergency stop button or to stop the generator automatically in case of a fire alarm, you can use the bypass connection between fastons J7 and J18 on the backside of the local control panel. See fig. 30. To do so, remove this bypass connection and then replace it by

an emergency switch or a potential free fire alarm switch with normally closed contacts

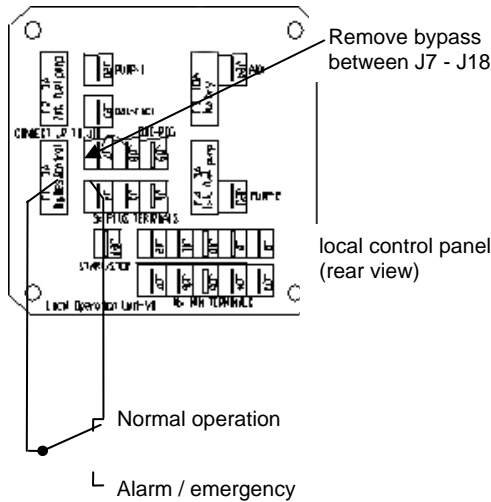

Fig. 30: Connection for emergency stop / fire alarm switch

### Automatic starting and stopping



Whisper Power cannot be held responsible for damage caused by the unattended running generator using the auto-start/stop mode or interval mode



Using the auto-start/stop (interval) mode the generator can start unexpectedly. When working on the electrical system, the 3 Amp fuse must be removed from the control panel and the battery plus cable must be removed from the battery.



In the delivery are warning stickers to stick on several parts of the electric installation (transfer switch, distribution box, etc.) to warn for automatic start

The Whisper Power Digital Diesel Control system offers several options for automatic starting and stopping.

Access to this menu and other menus could be blocked. For de-blocking and setting up this options refer to the APPENDIX of the DDC user's manual.

One of these options is to monitor a second battery (not being the starter battery) to start the generator automatically when the voltage of this battery drops below a certain setting.

Other names for this second battery are "auxiliary battery", "service battery", "users battery" or "consumers battery". We will refer to this battery as "the second battery" (BAT2). In some menus the starter battery could be indicated as "the first battery" (BAT1).

A sense wire to monitor the second battery should be connected (attention polarity!) to the connector on the back of the remote panel. Refer to fig. 29. The sense wires must be connected directly on the second battery before a main switch and be protected by a 3 Amps fuse. (Monitoring the generator starter battery does not require an extra sense connection)

### Settings

When one want to apply other settings than the factory settings refer to the DDC users manual, especially to the APPENDIX.

## 2 STARTER BATTERY

For starting, the Whisper requires a 12V starter battery with the following capacity:

Model	Minimum capacity
W-SQ6	60Ah
W-SQ8, 12	70Ah
W-SQ16	120Ah

The generating set can be connected with the main engine battery or have its own battery.

We strongly recommend the use of a separate battery for the generating set and to keep the wiring system for the vehicle engine and the domestic DC supply system completely separate and individually connected to separate batteries.

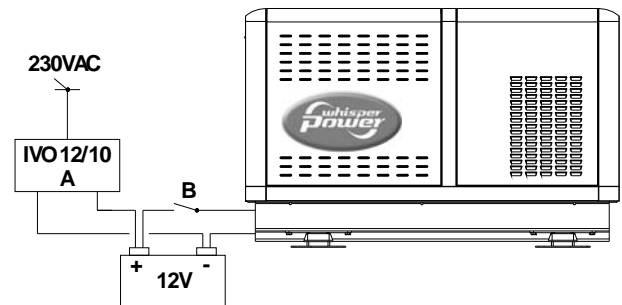

Fig. 31 Starter battery

However, the negative of all the batteries on the vehicle should be interconnected to avoid difference in the voltage level of the earth on different places causing trouble to electronic devices which might be in the system.

The above recommendation is not valid for vehicles having the starter battery of the vehicle engine or other auxiliary equipment positive grounded. When this is the case an expert should be consulted.

A battery switch may be used to interrupt the positive connection.

The starter battery is charged by the alternator on the engine. An additional battery charger will help to keep the battery in good condition when the generating set is not used.

A battery charger is not included in the standard supply. A high efficiency battery charging unit can be ordered from Whisper Power which is able to charge both the vehicles's main battery and the starter battery. Also a small charger can be used to charge the starter battery only, such as the IVO SMART 12/10. A battery switch and a charger are included in the battery installation kits, art. no. 40230210 (70Ah) or 40230220 (160Ah)

### 3 12V OR 24V DC TO DRIVE THE FAN

When applying 12V or 24 V DC to drive the fan of the radiators the fan should be wired with minimum 4 mm<sup>2</sup> cable according to the wiring diagram. The negative return wire should be of the same diameter. The return current should never be lead over the chassis.

The consumption of power by the 12V DC powered fan makes it necessary to install an additional 30 Amps battery charger to prevent the starter battery to be drained. A much larger battery (170Ah at least) is required. The battery charging winding in the generating set is not capable of powering the fan. Neither is the small charger that is included in the battery kit. Whisper Power supplies high quality battery chargers that continuously supply the rated power. Chargers of other suppliers are often rated to other standards and give the rated current (Amps) only for a short period if at all.

To avoid the need of an extra heavy battery charger a 230 Volt fan on the radiator is recommended. One should realize that the power for the fan must be deducted from the output power of the generating set.

### 4 OTHER RECOMMENDATIONS AND WARNINGS

The battery should be secured for poor road conditions and the terminals should be insulated. For extra safety the battery can be enclosed in a wooden, plastic, fibreglas etc. (non metal) box. Even when the earth return system is applied a negative battery cable should be used and the vehicle should not to be used as a conductor.

The battery cables are supplied in a standard length of 1.5 m, if longer cables are required a larger cross sectional area should be considered to compensate for voltage reduction.



When two batteries are used in series to provide a 24 Volt supply system, never take off 12 Volt (starting) power from one of these batteries. This will result in severe damage to both batteries within a short time.

Disconnect the battery leads if electrical welding is to be carried out, otherwise damage will be caused to the diodes of the alternator.



As explosive hydrogen gases may be discharged during charging, the battery should be located in a well ventilated room. Ensure that the supplied battery cable connectors are properly fitted and never remove during or shortly after charging as sparking can occur, which may ignite the hydrogen gasses.

### 2.5.5 AC power system (230 Volt)



The electric power supplied by the generator is of a high voltage and dangerous to people. Before working (installation) on the system read the sections on safety in the users manual.



Realise that people are not used to have 230V available on a vehicle. Put warning signs on wall sockets and on junction boxes. Instruct non-regular users of the vehicle. Warn maintenance personal of garages that do service on the vehicle.



Generators used on vehicles that are operated in a hazardous environment have often to fulfill special regulations and additional measures have to be taken accordingly.

Be sure that all electrical installations (including all safety systems) comply with all required regulations of the local authorities. All electrical safety/shutdown and circuit breaking systems have to be installed onboard as the generating set itself cannot be equipped with such equipment for every possible variation.

The vehicle's power supply system should be suitable and safe for the AC voltage which is applied and the power that will be generated. Special attention has to be paid on dividing the system in branches which are fused individually.

It is absolutely essential that each and every circuit in the electrical system is properly installed by a qualified electrician.

#### 1 FUSE

An output fuse (between the generating set and the electrical installation) should be installed to protect the installed electrical system. The following maximum single phase output current applies:

Model	Maximum single phase output current
W-SQ6	25 Amps
W-SQ8	35 Amps
W-SQ12	52 Amps
W-SQ16	70 Amps

The fuses must be of the slow reacting type. For electrical motors connected to the system, a motor protection switch must be installed

#### 2 GROUNDING

The AC alternator windings are not grounded.

The housing of the alternator and all other metal parts are grounded

To make a connection between "neutral" and "ground" is necessary as part of a specific insulation failure protection system.

It is possible that the electric installation in the vehicle must be protected against insulation failures. Methods of protection are subjected to rules that can be different depending on the use of the vehicle and local standards. Experts in this field should be consulted.

#### 3 CABLE

For the power cable we recommend the use of 3 wire single phase oil resistant cable with a sufficient cross sectional area. One wire for earth is included. For long cables it is recommended to apply cables with a larger cross section (refer to ISO 13297 annex A)

#### 4 TRANSFER SWITCH

A power source selector switch must be installed between the generating set and the vehicle's electrical supply system. This switch must ensure that all AC consumers can be switched off at once. This switch should also be installed to keep the generating set and shore (grid) power systems separate.

Transfer switches - to switch over from a land line to vehicle or from generating set to inverter - should be well designed to switch over all wires including neutral (and not only phases or line) and there should be provisions with the aid of timers to prevent relays from clattering.

Whisper Power recommends the installation of a Mass Systemswitch as the power source selector. This works automatically when the generating set is not running the input remains in the land line position and as soon as the generating set is running the Mass Systemswitch switches automatically after 10 seconds delay time over to the generating set position.



In all situations the transfer switches between land line, inverter and generator should switch both neutral and L1. Of course this is the case when using a Mass Systemswitch.

### 3 INSTALLATION SPECIFICATIONS

#### 3.1 GENERAL

- 1 Make a hole for combustion air in the sound shield. Mount an air inlet filter (if required)
- 2 Mount the generating set directly, without additional vibration dampers, on a solid surface.
- 3 Mount the cooling system for the engine
- 4 Mount the cooling system for the alternator
- 5 Connect exhaust system.
- 6 Connect 'fuel supply line' to the water separator/ fuel filter.
- 7 Connect 'fuel return line' to the fuel tank.
- 8 Connect remote panel (just plug in).
- 9 Connect the AC cable from the AC box to the power source selector (or Systemswitch).
- 10 Connect plus and minus from the 12V starter battery to the battery cables.
- 11 Connect the power supply of the radiators
- 12 Install a Whisper Power battery charger. (optional)

#### 3.2 COMMISSION TABLE

- 1 Check if a hole for combustion air intake is in the sound shield. Also check if an air inlet filter for combustion air is necessary and has been installed
- 2 Check if the cooling system for the engine is properly installed. Note that air traps must be avoided.
- 3 Check if the cooling system for the alternator is properly installed. Note that air traps must be avoided.
- 4 Check if the exhaust system is properly installed. Check maximum length of exhaust hose, diameter of exhaust piping.
- 5 Check all coolant connections.
- 6 Check the AC cables and the grounding.
- 7 Check if an AC breaker is installed before or after the power source selector. When there is only a circuit breaker, use it to disconnect the generating set from the grid.

- 8 Check all DC connections, check if the battery switch/ circuit breaker is closed.
- 9 Open the fuel valve. Check if there are no air leaks in the fuel supply line, and check if the lift of the fuel is less than 1 meter. Check if there is no air in the water fuel separator.
- 10 Check if the air intake in the canopy is not blocked.
- 11 Check the oil level and colour of the oil. Check the coolant level of both the alternator cooling and the engine cooling
- 12 To bleed the fuel system:
  - W-SQ6, 8, and 12: push the "Start" button on the local control (not on the remote panel) and hold at least 5 seconds and as long as necessary to bleed the system.
  - W-SQ16: use the manual pump by turning the cap loose and pumping as long as necessary to bleed the system. See chapter 4.2.2 of the user's manual.
- 13 Start the engine by pushing the start button
- 14 Check when the generating set is running, the delay of 5 to 10 seconds in the power source selector transfer.
- 15 Check voltage and frequency under 'no load' conditions.
- 16 Check voltage and frequency under 'full load' conditions.
- 17 Check if the battery charger of the generating set is working (max. 14.5 Volt).
- 18 Close the sound shield and check the noise level.
- 19 Stop the generating set and check the engine again for leakages of oil, fuel or coolant.

Installation checklist available on our website:  
[www.whisperpower.eu](http://www.whisperpower.eu).

Commissioning form available on our website:  
[www.whisperpower.eu](http://www.whisperpower.eu).



### 3.3 TECHNICAL DATA

#### W-SQ6 EN W-SQ8

Model	W-SQ6	W-SQ8
Dimensions (l x w x h)	80.5 x 52.5 x 58.0 cm	90 x 58 x 63 cm
Weight including sound shield	240kg	335 kg
Max. operation angle	25°	25°
Remote panel 15 m cable	Digital Diesel Control System	
Battery capacity min.	12V / 60Ah	12V / 70Ah
Fuel consumption	1,5 – 4 l/hr, load dependent	
Model fuel pump	Electrical driven 12V	Electrical driven 12V
Max lift fuel pump	1m	1m
Cooling	Radiator cooling	Radiator cooling
Cooling pump	Whisper Power self priming raw water impeller pump, PTO driven	
Model cooling pump	M	M12
Minimum water supply	9-15 l/min	18-22 l/min
Alternator	synchronous brushless, maintenance free, water cooled	
Voltage regulation	capacitor (+ optional: AVR )	
Output power at 50Hz, power factor cos phi = 1	5.7 kW*	8 kW*
Battery charger (alternator including regulator):	40 Amps	50 Amps

\* Note that this value must be reduced by the power to drive the cooling fans of the radiators.

#### W-SQ12 AND W-SQ16

Model	W-SQ12	W-SQ16
Dimensions (l x w x h)	106 x 58 x 63 cm	116 x 58 x 70 cm
Weight including sound shield	380 kg	440kg
Max. operation angle	25°	25°
Remote panel 15 m cable	Digital Diesel Control System	
Battery capacity min.	12V / 70Ah	12V / 120Ah
Fuel consumption	1,5 – 4 l/hr, load dependent	
Model fuel pump	Electrical driven 12V	Mechanical driven, manual priming
Max lift fuel pump	1m	1m
Cooling	Radiator cooling	Radiator cooling
Cooling pump	Whisper Power self priming raw water impeller pump, PTO driven	
Model cooling pump	M12	M16
Minimum water supply	18-22 l/min	20-25 l/min
Alternator	synchronous brushless, maintenance free, water cooled	
Voltage regulation	capacitor (+ optional: AVR )	
Output power at 50Hz, power factor cos phi = 1	12 kW*	16 kW*
Battery charger (alternator including regulator):	50 Amps	50 Amps

\* Note that this value must be reduced by the power to drive the cooling fans of the radiators.

### 3.4 INSTALLATION MATERIALS

#### BATTERY INSTALLATION KIT 70 Ah for W-SQ6, 8 and 12

no	qty	article no	description	dimensions
51	1	42000700	Whisper Power AGM Battery 12V/70Ah	70Ah
52	1	43011000	battery charger IVO SMART 12/10	
53	1	48060100	battery terminal +	M8
54	1	48060200	battery terminal -	M8
55	1	48456902	isolation cap	
56	1	48456914	isolation cap	
57	1	49009005	battery switch	250 Amp
58	4	4503002508	cable connectors	M8x25
<b>TOTAL</b>		40230210	<b>BATTERY INSTALLATION KIT 70 Ah</b>	

#### BATTERY INSTALLATION KIT 160 Ah for W-SQ16

no	qty	article no	description	dimensions
51	1	42001600	Whisper Power AGM Battery 12V/160Ah	160Ah
52	1	43011000	battery charger IVO SMART 12/10	
53	1	48060100	battery terminal +	M8
54	1	48060200	battery terminal -	M8
55	1	48456902	isolation cap	
56	1	48456914	isolation cap	
57	1	49009005	battery switch	250 Amp
58	4	4503003508	cable connectors	M8x35
<b>TOTAL</b>		40230220	<b>BATTERY INSTALLATION KIT 160 Ah</b>	

#### FUEL KIT

no	qty	article no	description	dimensions
41	2	50221203	Straight coupling	8 mm
42	1	50230090	Fuel strainer/water separator	M14x1.5 mm
43	2	50221618	Parallel male stud coupling	M14 - 8 mm
44	2	50221644	Reducing male nipple	M14-M16 60 gr.
45	2	50221615	Hose connection	8 mm
46	2	50221616	Nut coupling	M16x1.5 mm
47	1	50221252	Nipple hose pipe	8 mm
48	4	50221522	Hose clamps	10-16 mm
49	2	50221632	Gasket ring	14x20x1.5 mm
<b>TOTAL</b>		40230205	<b>FUEL KIT</b>	

#### OPTIONAL INSTALLATION MATERIALS

no	qty	article no	description	dimensions
50	1	50222020	copper fuel pipe	6x8 mm
51	1	50220063	fuel hose	8x16 mm

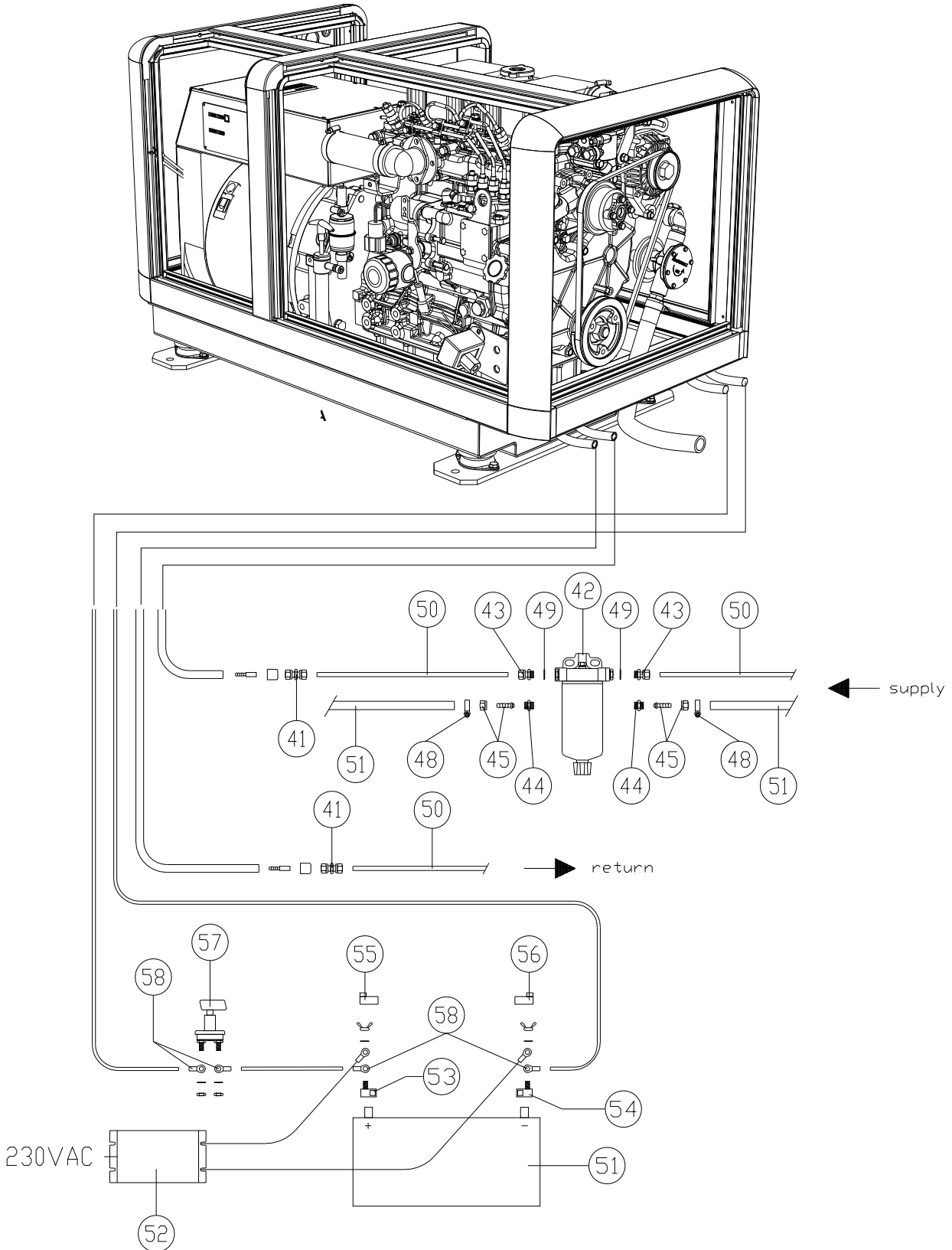

Fig. 32: Installation materials battery and fuel kit

Included are all fittings to fit copper pipes 8 mm outer diameter or rubber fuel hoses 8 mm inner diameter, or both

**DRY EXHAUST KIT 1½” for W-SQ6, 8, 12 and 16**

no	qtt	article no	description
61	1	50220043	“Exh.hose SS 500mm fem./male 11/2”
62	1	50220042	Insul. blanket 35x60 exhaust hose 1 1/2
63	1	50230523	“Absorbtion muffler steel 11/2”
64	1	50230524	“Ressonance muffler steel 11/2”
65	1	50230525	“Insul. blanket 80x75 muffler SDHC 11/2”
66	2	50221403	“Pipe nipple 11/2”x300mm galvanised”
67	2	50221423	“Parallel male coupling 11/2” galvanised”
68	2	50221413	“Straight coupling f/f 11/2”galvanised”
69	3	50221663	U-clamp 48 mm M10
70	3	50221664	Bracket U-clamp 25cm M10/48mm passivated
71	6	50211406	Washer SP M10
72	6	50211447	Washer spring SP M10
73	6	50211466	Nut hexogonal SP M10
75	1	50221473	“Elbow 90 degr m/f gavalvanised 11/2”
<b>TOTAL</b>		40201875	<b>DRY EXHAUST KIT 1½” for W-SQ6, 8, 12 and 16</b>

**RADIATOR COOLING KIT ALTERNATOR 230VAC for W-SQ6, 8 and 12**

no	qtt	article no	description
31	1	50230304	Radiator cooler AP 300/2 E 230VAC
32	2	50221103	“Straight reducer m/f 1”-3/4”
33	1	50221063	“Male nipple 3/4”
34	1	50221043	“TEE fittings 3/4”
35	3	50221004	Male hose connection 3/4x20
38	1	50212405	Temperature switch 35-45 degr
39	4	50201121	Vibration mounting 30x25
40	4	50211152	Bolt hexagonal ZP M8x16
41	8	50211465	Nut hexogonal SP M8
42	8	50211405	Washer SP M8
43	8	50211445	Washer spring SP M8
44	8	50220011	“Hose vacum SAE100R4 (3/4”) 19x31,5mm
45	6	50221502	Hose clamp stainless19-29
46	8	50221599	Hose support 35x15 mm galvanised
47	1	50230529	Bracket expansion tank for 50230531
47	1	50230531	Expansion tank 20 mm
47	1	50230532	Cap tank 0502 30531
<b>TOTAL</b>		40201878	<b>RADIATOR COOLING KIT ALTERNATOR 230VAC for W-SQ6, 8 and 12</b>

**RADIATOR COOLING KIT ALTERNATOR 12VDC FOR W-SQ6**

Same as article no. 40201878, except:

no	qtt	article no	description
31	1	50230302	Radiator cooler AP 300/2 E 12VDC
<b>TOTAL</b>		40201872	<b>Radiator cooling kit alternator 12VDC for W-SQ6</b>

**RADIATOR COOLING KIT ALTERNATOR 24VDC FOR W-SQ6**

Same as article no. 50201878, except:

no	qtt	article no	description
31	1	50230303	Radiator cooler AP 300/2 E 24VDC
<b>TOTAL</b>		40201868	<b>Radiator cooling kit alternator 24VDC for W-SQ6</b>

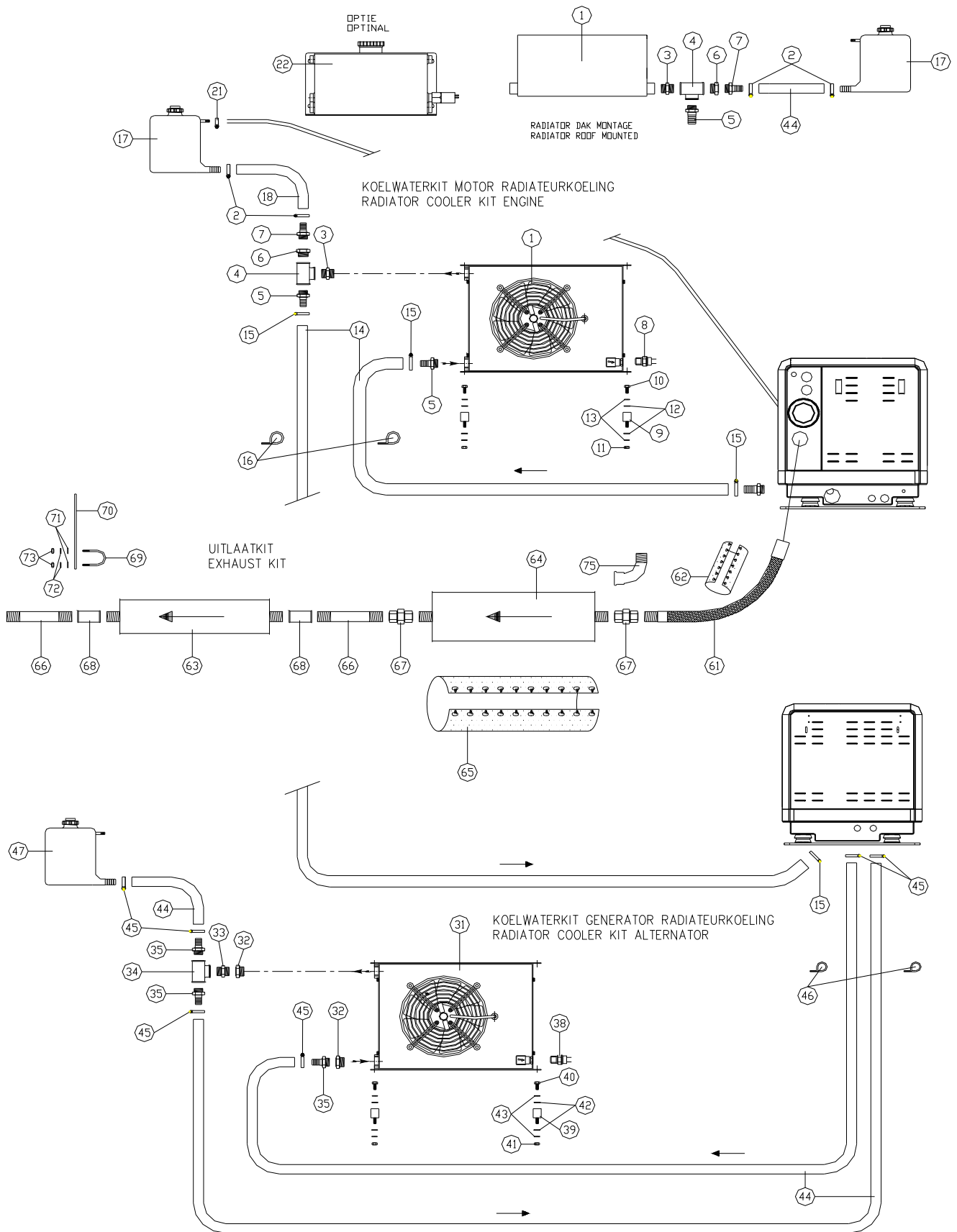

Figure 33: radiator cooling kit engine, exhaust kit and radiator cooling kit alternator

**RADIATOR COOLING KIT ALTERNATOR 230VAC W-SQ16**

no	qtt	article no	description
31	1	50230307	Radiator AP 430 230VAC
32	1	50221103	"Straight reducer m/f 1"-3/4"
33	1	50221064	"Male nipple 1"
34	1	50221044	"TEE fitting 1"
35	2	50221010	Male hose connection 1x25
35	1	50221004	Male hose connection 3/4x20
38	1	50212405	Temperature switch 35-45 degr
39	4	50201121	Vibration mounting 30x25
40	4	50211152	Bolt hexagonal ZP M8x16
41	4	50211465	Nut hexagonal SP M8
42	4	50211405	Washer SP M8
43	8	50211445	Washer spring SP M8
44	6	50220012	"Cooling water hose smooth (1") 25x34 mm"
44	1.5	50220011	"Cooling water hose smooth (3/4")18x27 mm"
45	2	50221502	Hose clamp stainless19-29
45	4	50221503	Hose clamp stainless 26-38
47	8	50221599	Hose support stainless 35x12 mm
47	1	50230529	Bracket expansion tank for 50230531
47	1	50230532	Cap tank 0502 30531
47	1	50230531	Expansion tank 20 mm
<b>TOTAL</b>		40201888	<b>Radiator cooling kit alternator 230VAC W-SQ16</b>

**RADIATOR COOLING KIT ENGINE 230VAC W-SQ6**

no	qtt	article no	description
1	1	50230304	Radiator cooler AP 300/2 E 230VAC
2	2	50221502	Hose clamp stainless19-29
3	1	50221064	"Male nipple 1"
4	1	50221044	"TEE fitting 1"
5	2	50221010	Male hose connection 1x25
6	1	50221103	"Straight reducer m/f 1"-3/4"
7	1	50221004	Male hose connection 3/4x20
8	1	50212409	Temperature switch 87-82 degr
9	4	50201121	Vibration mounting 30x25
10	4	50211152	Bolt hexagonal ZP M8x16
11	4	50211465	Nut hexagonal SP M8
12	8	50211405	Washer SP M8
13	8	50211445	Washer spring SP M8
14	6	50220012	"Hose vacuum SAE100R4 (1") 25,4x38mm"
15	4	50221503	Hose clamp stainless 26-38
16	8	50221599	Hose support stainless 35x12 mm
17	1	50230529	Bracket expansion tank for 50230531
17	1	50230531	Expansion tank 20 mm
17	1	50230532	Cap tank 0502 30531
18	1.5	50220011	"Hose vacuum SAE100R4 (3/4") 19x31,5mm"
21	1	50221532	Hose clamp stainless mini 9-11
<b>TOTAL</b>		40201879	<b>Radiator cooling kit engine 230VAC W-SQ6</b>

**RADIATOR COOLING KIT ENGINE 12VDC FOR W-SQ6**

Same as article no. 40201879, except:

no	qtt	article no	description
31	1	50230302	Radiator cooler AP 300/2 E 12VDC
<b>TOTAL</b>		40201871	<b>Radiator cooling kit engine 12VDC W-SQ6</b>

**RADIATOR COOLING KIT ENGINE 12VDC FOR W-SQ6**

Same as article no. 40201879, except:

no	qtt	article no	description
31	1	50230303	Radiator cooler AP 300/2 E 24VDC
<b>TOTAL</b>		40201880	<b>Radiator cooling kit engine 24VDC W-SQ6</b>

**RADIATOR COOLER KIT ENGINE 230VAC W-SQ8**

no	qtt	article no	description
1	1	50230307	Radiator AP 430 230VAC W-SQ8
2	2	50221502	Hose clamp stainless19-29
3	1	50221064	"Male nipple 1"
4	1	50221044	T-stuk-1"
5	2	50221014	Male hose connection 1x35
6	1	50221103	"Straight reducer m/f 1"-3/4"
7	1	50221004	Male hose connection 3/4x20
8	1	50212409	Temperature switch 87-82 degr
9	4	50201121	Vibration mounting 30x25
10	4	50211152	Bolt hexagonal ZP M8x16
11	4	50211465	Nut hexagonal SP M8
12	4	50211405	Washer SP M8
12	4	50211437	Washer mudguard SP 8x30x1,5
13	8	50211445	Washer spring SP M8
14	6	50220013	"Hose vacuum SAE100R4 (1 1/4") 31,8x45mm
15	4	50221504	Hose clamp stainless 38-50
16	8	50221597	Hose support SP 45x25 mm galvanised
17	1	50230529	Bracket expansion tank for 50230531
17	1	50230531	Expansion tank 20 mm
17	1	50230532	Cap tank 0502 30531
18	1.5	50220011	"Hose vacuum SAE100R4 (3/4") 19x31,5mm
21	1	50221532	Hose clamp stainless mini 9-11
<b>TOTAL</b>		40201864	<b>Radiator cooler kit engine 230VAC W-SQ8</b>

**RADIATOR COOLER KIT ENGINE 230VAC W-SQ12 and W-SQ16**

no	qtt	article no	description
1	1	50230311	Radiator AP 430/2 230 VAC W-SQ12 and 16
2	2	50221502	Hose clamp stainless19-29
3	1	50221064	"Male nipple 1"
4	1	50221044	T-stuk-1"
5	2	50221014	Male hose connection 1x35
6	1	50221103	"Straight reducer m/f 1"-3/4"
7	1	50221004	Male hose connection 3/4x20
8	1	50212409	Temperature switch 87-82 degr
9	4	50201121	Vibration mounting 30x25
10	4	50211152	Bolt hexagonal ZP M8x16
11	4	50211465	Nut hexagonal SP M8
12	4	50211405	Washer SP M8
12	4	50211437	Washer mudguard SP 8x30x1,5
13	8	50211445	Washer spring SP M8
14	6	50220013	"Hose vacuum SAE100R4 (1 1/4") 31,8x45mm
15	4	50221504	Hose clamp stainless 38-50
16	8	50221597	Hose support SP 45x25 mm galvanised
17	1	50230529	Bracket expansion tank for 50230531
17	1	50230531	Expansion tank 20 mm
17	1	50230532	Cap tank 0502 30531
18	1.5	50220011	"Hose vacuum SAE100R4 (3/4") 19x31,5mm
21	1	50221532	Hose clamp stainless mini 9-11
			Optional
<b>TOTAL</b>		40201877	<b>Radiator cooler kit engine 230VAC W-SQ12 and 16</b>

**OPTIONAL INSTALLATION MATERIALS**

no	qty	article no	description
22	1	50230535	Expansion tank 7L + low level alarm switch



## 4 DIAGRAMS & DRAWINGS

### 4.1 LAYOUT GENERATOR CONTROL FOR W-SQ6, 8 AND 12 WITH 230VAC FAN

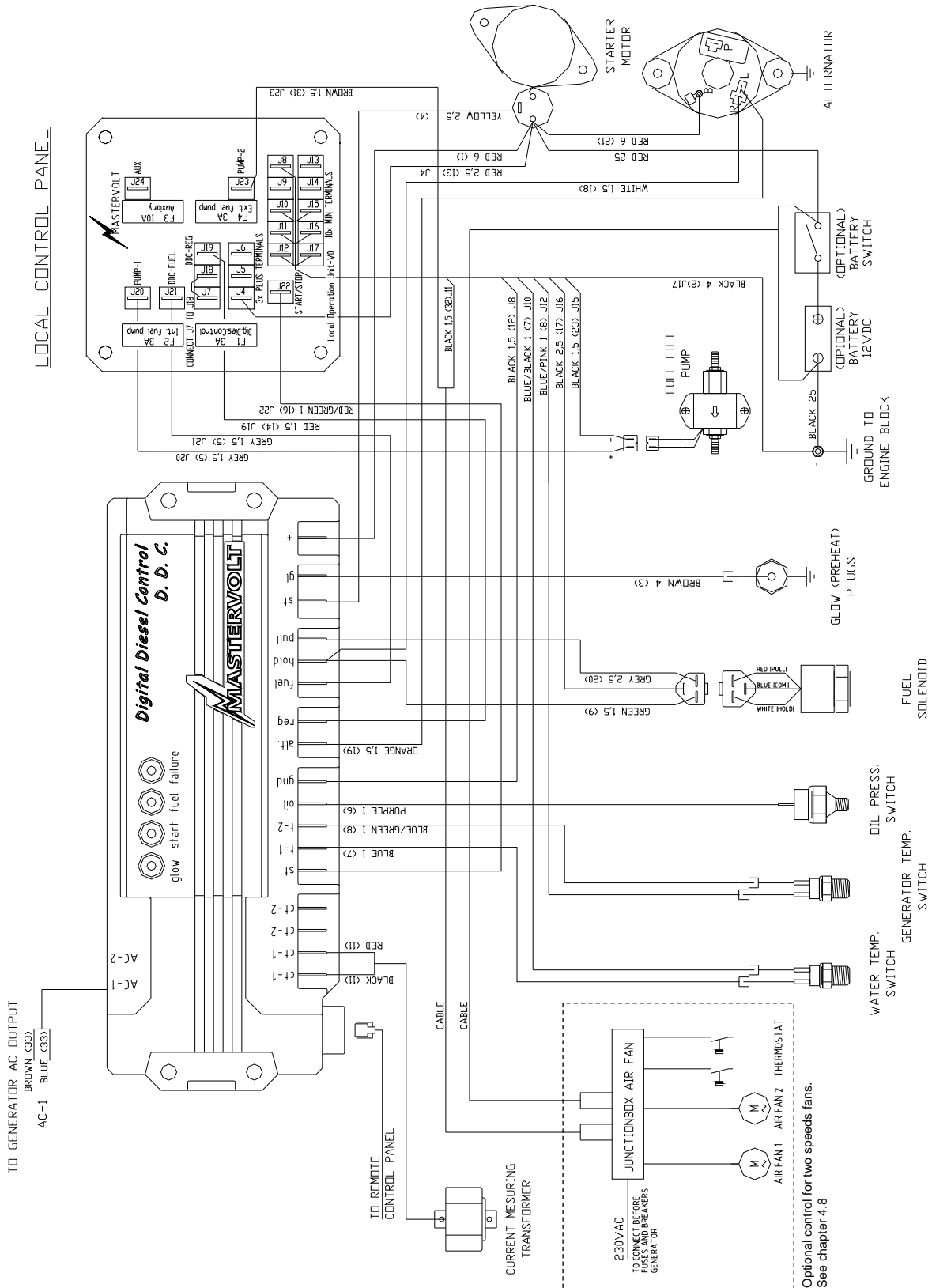

Fig. 34: Layout generator control for W-SQ6, 8 and 12 with 230VAC radiator fan

### 4.2 LAYOUT GENERATOR CONTROL FOR W-SQ6 WITH 12VDC FAN

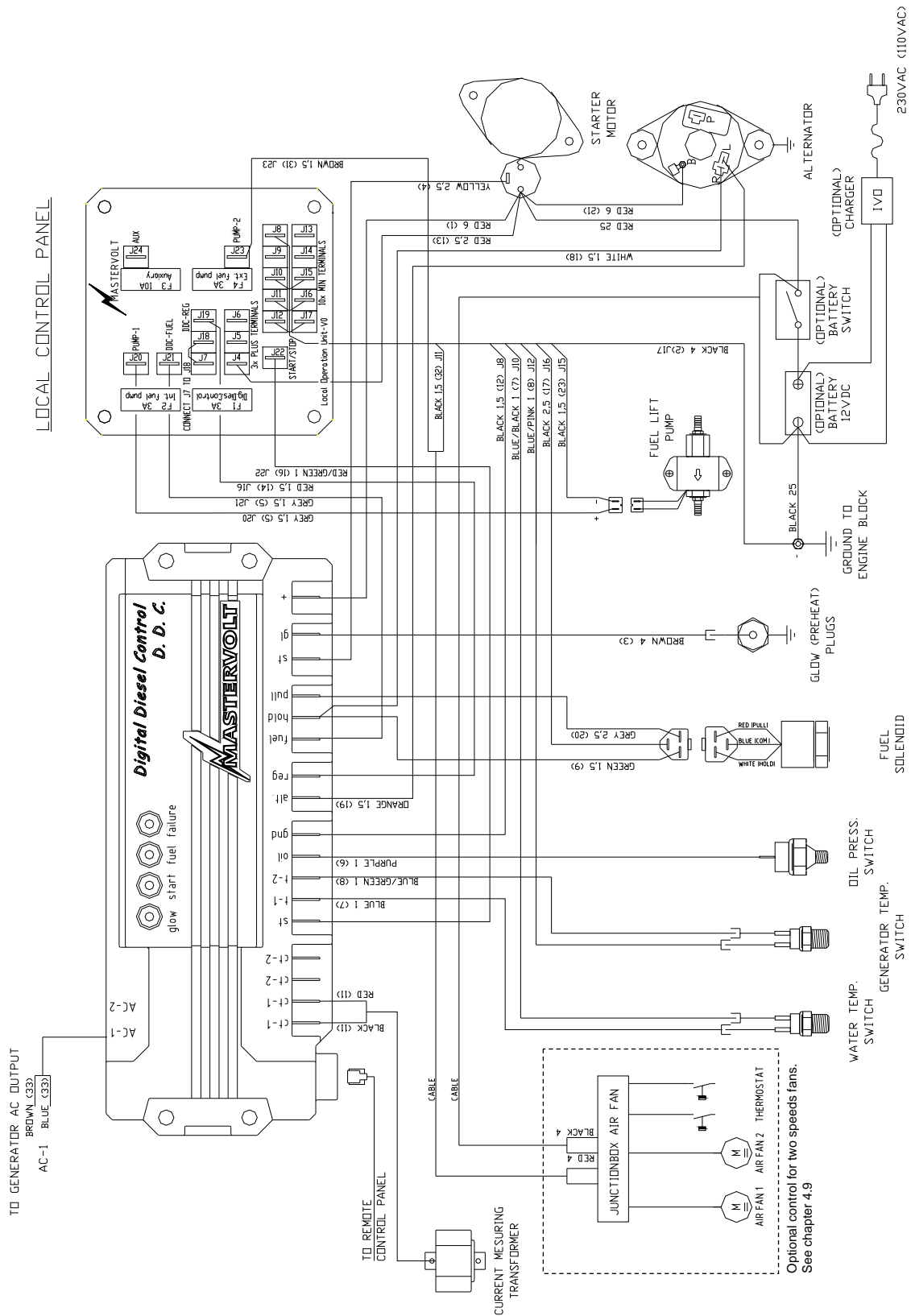

Fig. 35: Layout generator control for W-SQ6 with 12VDC radiator fan

### 4.3 LAYOUT GENERATOR CONTROL FOR W-SQ6 WITH 24VDC FAN

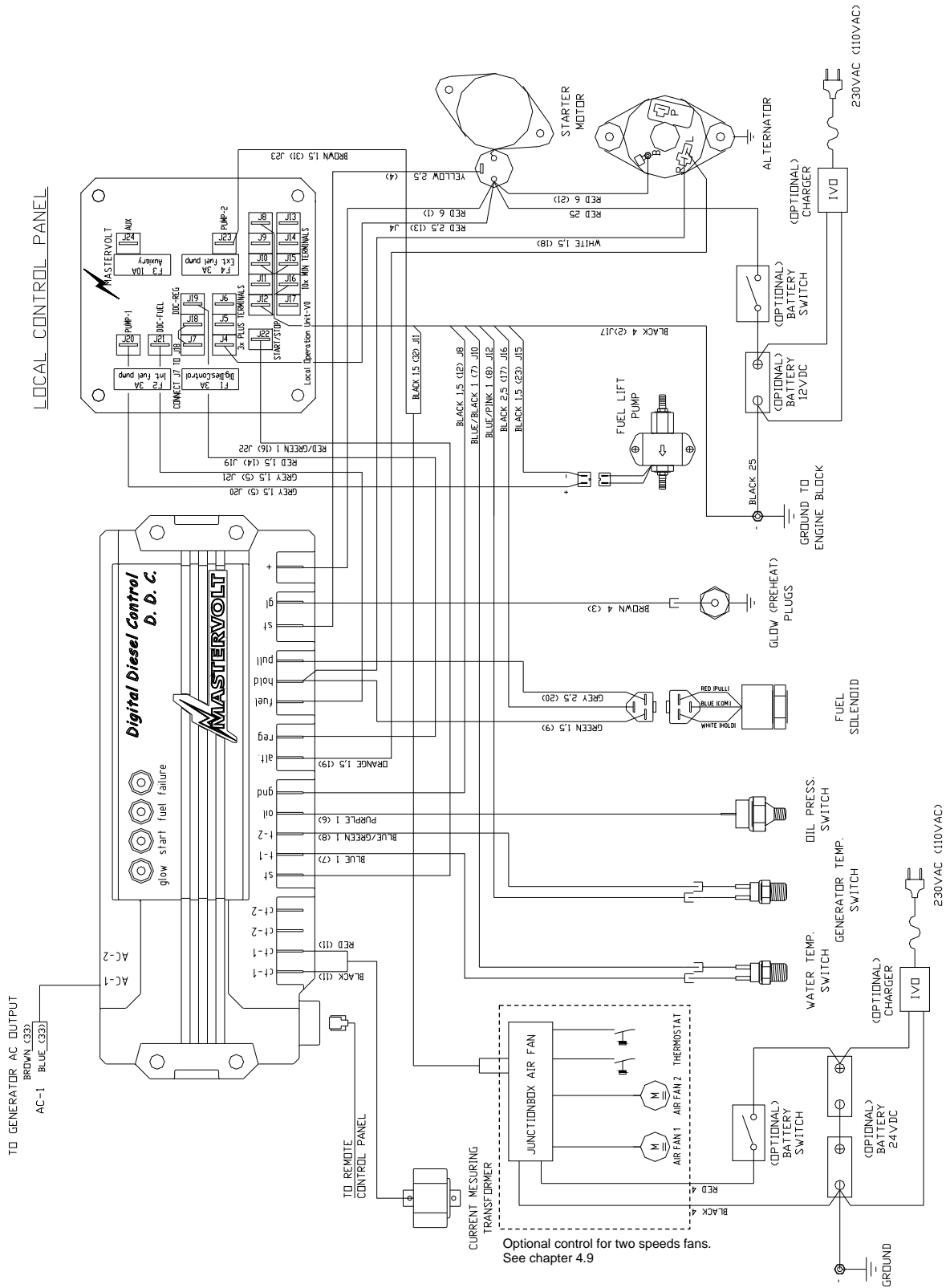

Fig. 36: Layout generator control for W-SQ6 with 24VDC radiator fan

### 4.4 LAYOUT GENERATOR CONTROL FOR W-SQ16 WITH 230VAC FAN

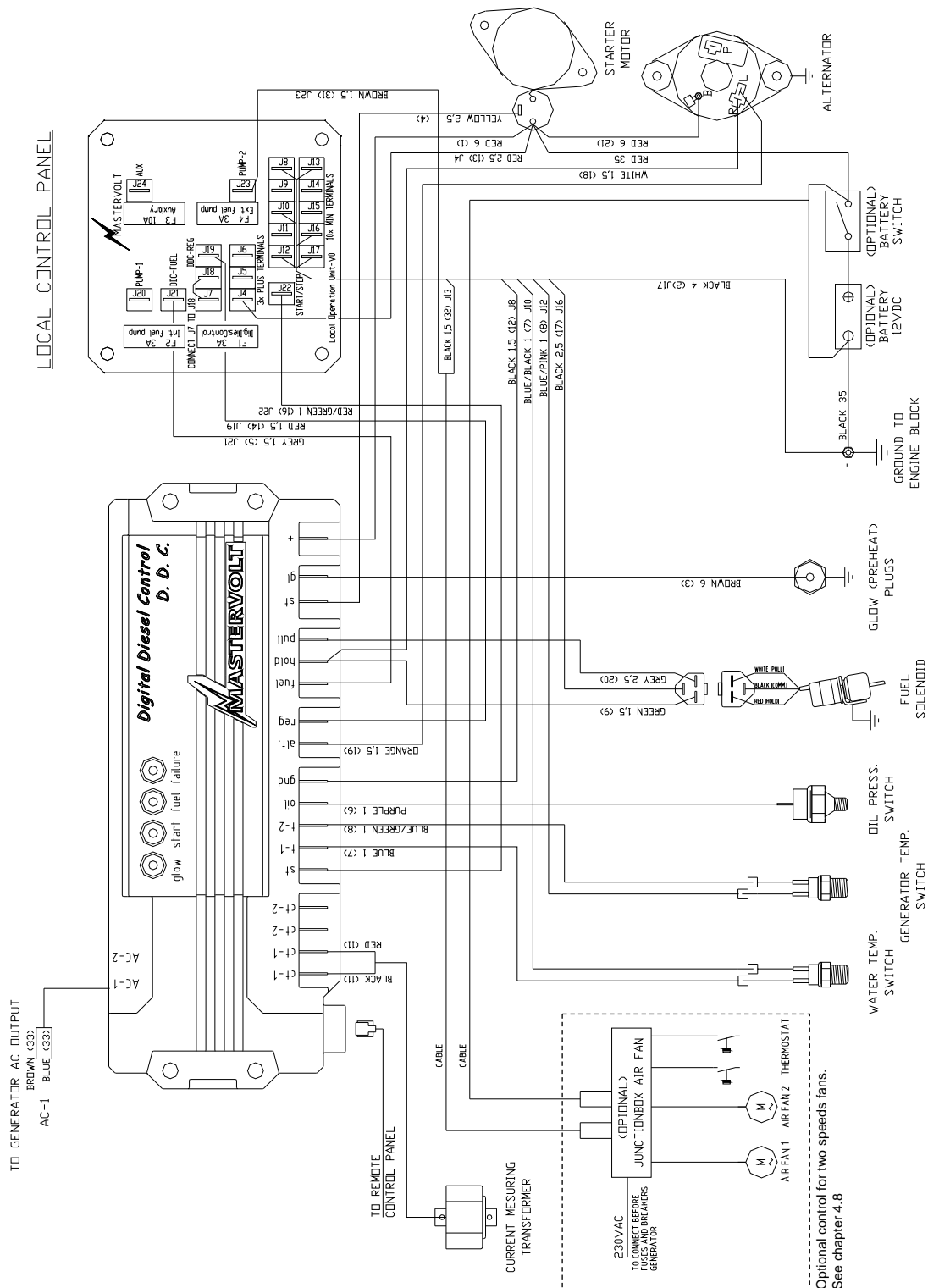

Fig. 37: Layout generator control for W-SQ16 with 230VAC radiator fan

#### 4.5 WIRING COLOURS W-SQ6, 8 AND 12

	Cable code number	colour	cross section
battery > starter motor		red	25 mm <sup>2</sup>
starter motor > DDC	1	red	6 mm <sup>2</sup>
starter motor > LCP	13	red	2,5 mm <sup>2</sup>
battery > ground		black	25 mm <sup>2</sup>
ground > LCP ground (GND)	2	black	4 mm <sup>2</sup>
DDC > glow plugs	3	brown	4 mm <sup>2</sup>
DDC > starter solenoid	4	yellow	2,5 mm <sup>2</sup>
LCP > fuel lift pump +	5	brown	1,5 mm <sup>2</sup>
LCP > fuel lift pump -	15	black	1,5 mm <sup>2</sup>
DDC > LCD	5	grey	1,5 mm <sup>2</sup>
DDC > oil pressure switch	6	purple	1 mm <sup>2</sup>
LCP > oil pressure switch	6	purple/black	1 mm <sup>2</sup>
DDC > water temperature switch	7	blue	1 mm <sup>2</sup>
LCP > water temperature switch	7	blue/black	1 mm <sup>2</sup>
DDC > exhaust temperature switch	8	blue/green	1 mm <sup>2</sup>
LCP > exhaust temperature switch	8	blue/rose	1 mm <sup>2</sup>
DDC > fuel solenoid (hold)	9	green	1,5 mm <sup>2</sup>
DDC > fuel solenoid (pull)	20	pink	1,5 mm <sup>2</sup>
DDC > fuel solenoid (com.)	17	black	1,5 mm <sup>2</sup>
B+ terminal alternator > starter motor	21	red	6 mm <sup>2</sup>
DDC > R terminal alternator	18	wit	1,5 mm <sup>2</sup>
DDC > L terminal alternator	19	orange	1,5 mm <sup>2</sup>
DDC > current measuring transformer	11	black	1 mm <sup>2</sup>
DDC > current measuring transformer	11	red	1 mm <sup>2</sup>
DDC > LCP	12	black	1,5 mm <sup>2</sup>
DDC > LCP	14	red	1,5 mm <sup>2</sup>
DDC > LCP	16	red/green	1,5 mm <sup>2</sup>
DDC > generator AC output	33	brown	1 mm <sup>2</sup>
DDC > generator AC output	33	blue	1 mm <sup>2</sup>

#### 4.6 WIRING COLOURS W-SQ16

	Cable code number	colour	cross section
battery > starter motor		red	35 mm <sup>2</sup>
starter motor > DDC	1	red	6 mm <sup>2</sup>
starter motor > LCP	13	red	2,5 mm <sup>2</sup>
battery > ground		black	35 mm <sup>2</sup>
ground > LCP ground (GND)	2	black	4 mm <sup>2</sup>
DDC > glow plugs	3	brown	4 mm <sup>2</sup>
DDC > starter solenoid	4	yellow	2,5 mm <sup>2</sup>
DDC > LCD	5	grey	1,5 mm <sup>2</sup>
DDC > oil pressure switch	6	purple	1 mm <sup>2</sup>
LCP > oil pressure switch	6	purple/black	1 mm <sup>2</sup>
DDC > water temperature switch	7	blue	1 mm <sup>2</sup>
LCP > water temperature switch	7	blue/black	1 mm <sup>2</sup>
DDC > exhaust temperature switch	8	blue/green	1 mm <sup>2</sup>
LCP > exhaust temperature switch	8	blue/rose	1 mm <sup>2</sup>
DDC > fuel solenoid (hold)	9	green	1,5 mm <sup>2</sup>
DDC > fuel solenoid (pull)	20	pink	2,5 mm <sup>2</sup>
DDC > fuel solenoid (com.)	17	black	2,5 mm <sup>2</sup>
B+ terminal alternator > starter motor	21	red	6 mm <sup>2</sup>
DDC > R terminal alternator	18	wit	1,5 mm <sup>2</sup>
DDC > L terminal alternator	19	orange	1,5 mm <sup>2</sup>
DDC > current measuring transformer	11	black	1 mm <sup>2</sup>
DDC > current measuring transformer	11	red	1 mm <sup>2</sup>
DDC > LCP	12	black	1,5 mm <sup>2</sup>
DDC > LCP	14	red	1,5 mm <sup>2</sup>
DDC > LCP	16	red/green	1,5 mm <sup>2</sup>
DDC > generator AC output	33	brown	1 mm <sup>2</sup>
DDC > generator AC output	33	blue	1 mm <sup>2</sup>

DDC=Digital Diesel Control Unit

LCP=Local Control Panel

## 4.7 AC WIRING DIAGRAM 230V / 50HZ

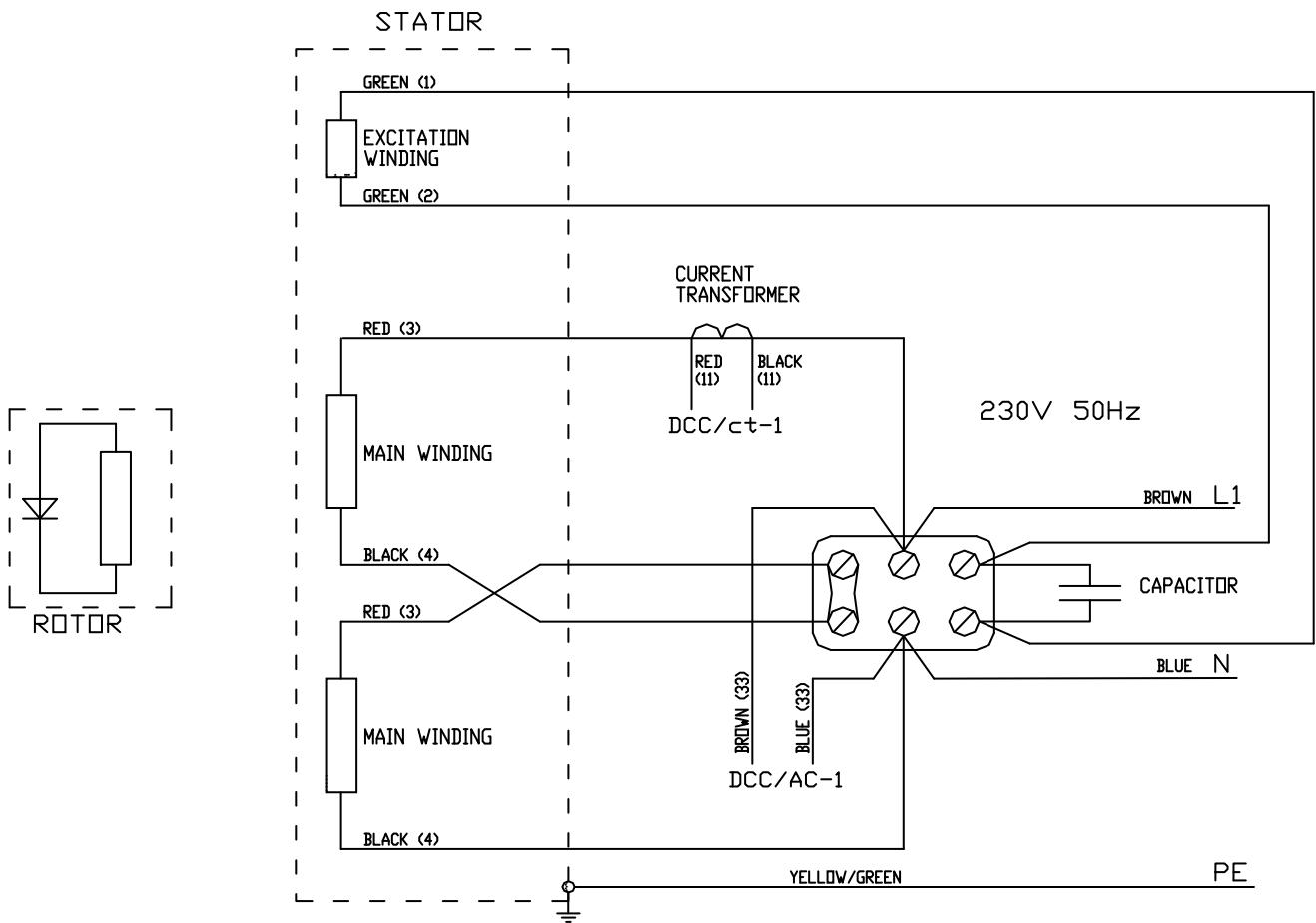
 EARTH AND NEUTRAL  
NOT CONNECTED

EARTH AND NEUTRAL CONNECTED

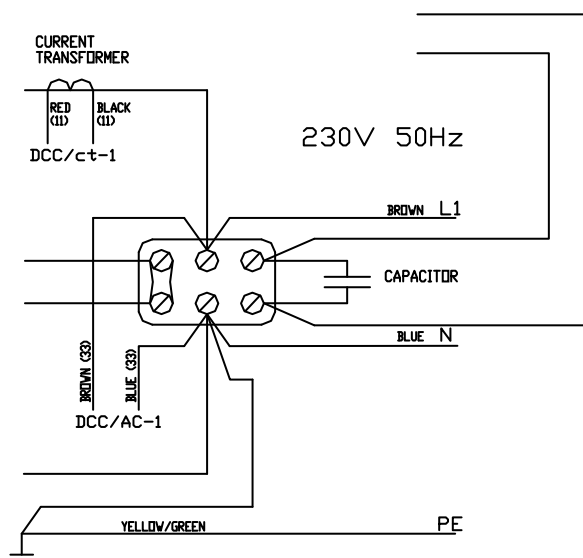

Fig. 38: AC wiring diagram

### 4.8 ELECTRICAL DIAGRAM RADIATOR FAN CONTROL 230VAC

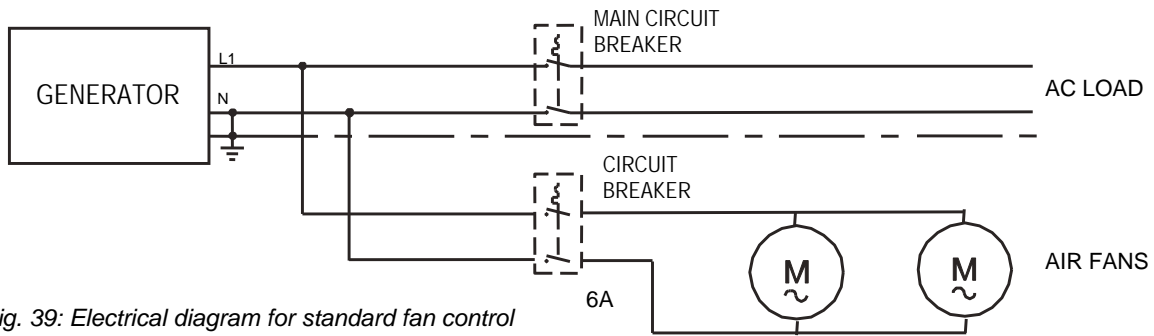

Fig. 39: Electrical diagram for standard fan control using 230V AC radiator fans

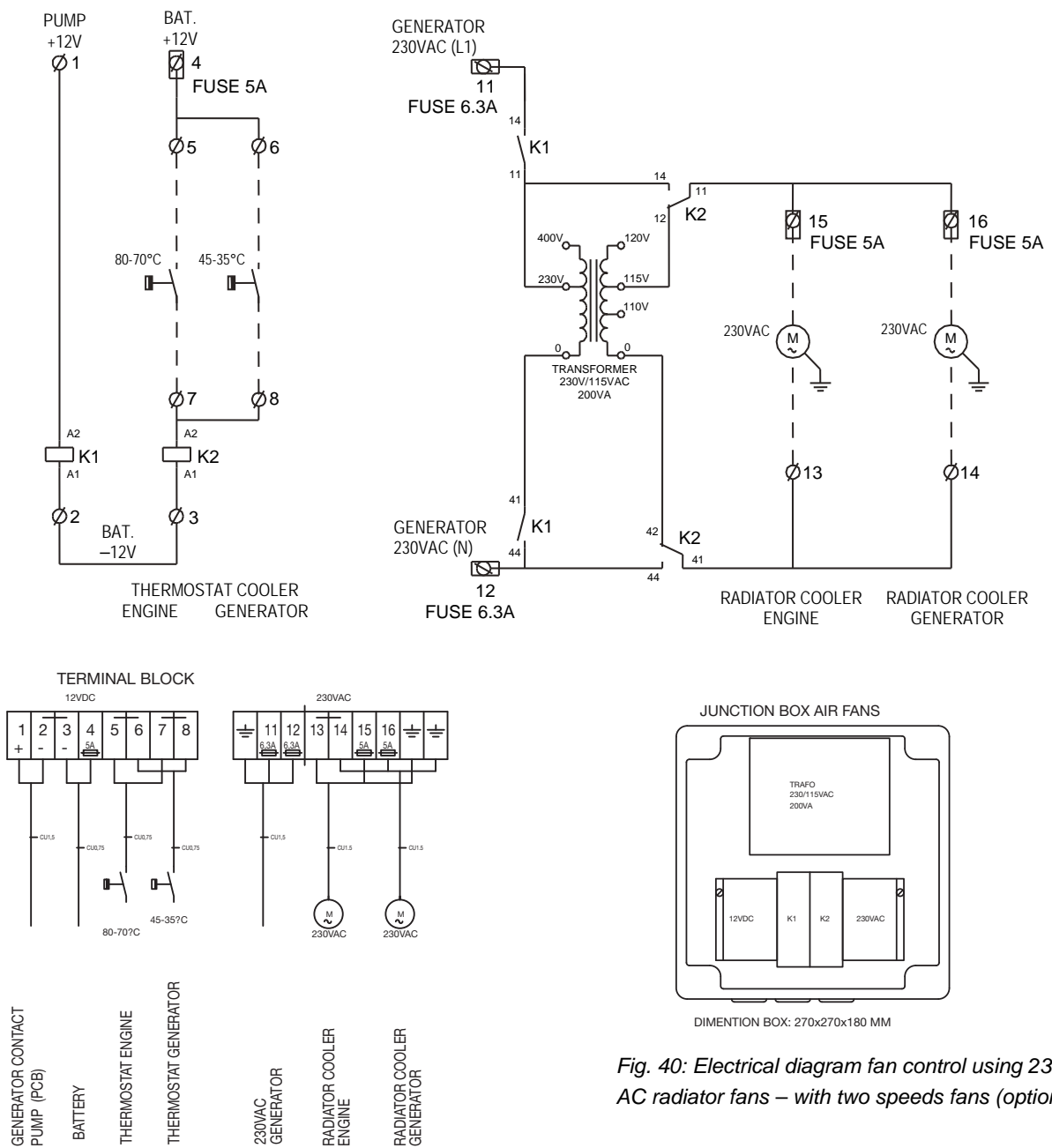

Fig. 40: Electrical diagram fan control using 230V AC radiator fans – with two speeds fans (optional)



**4.9 ELECTRICAL DIAGRAM RADIATOR FAN CONTROL 12 / 24 VDC**

Fig. 41: Electrical diagram fan control using 12V or 24V DC radiator fans (optional)

#### 4.10 WIRING DIAGRAM ELECTRONIC GOVERNOR (STANDARD FOR W-SQ6, 8 AND 12)

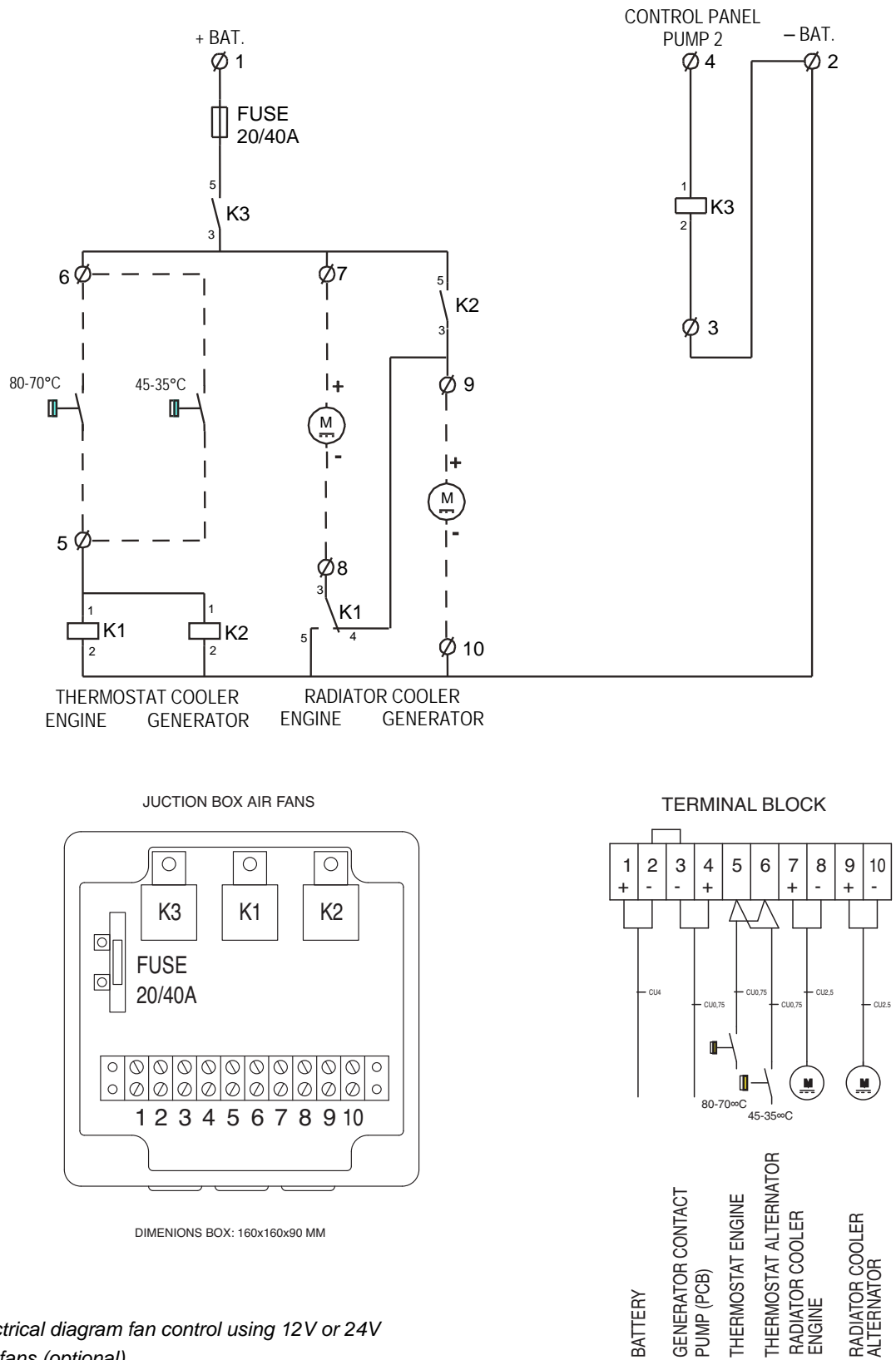
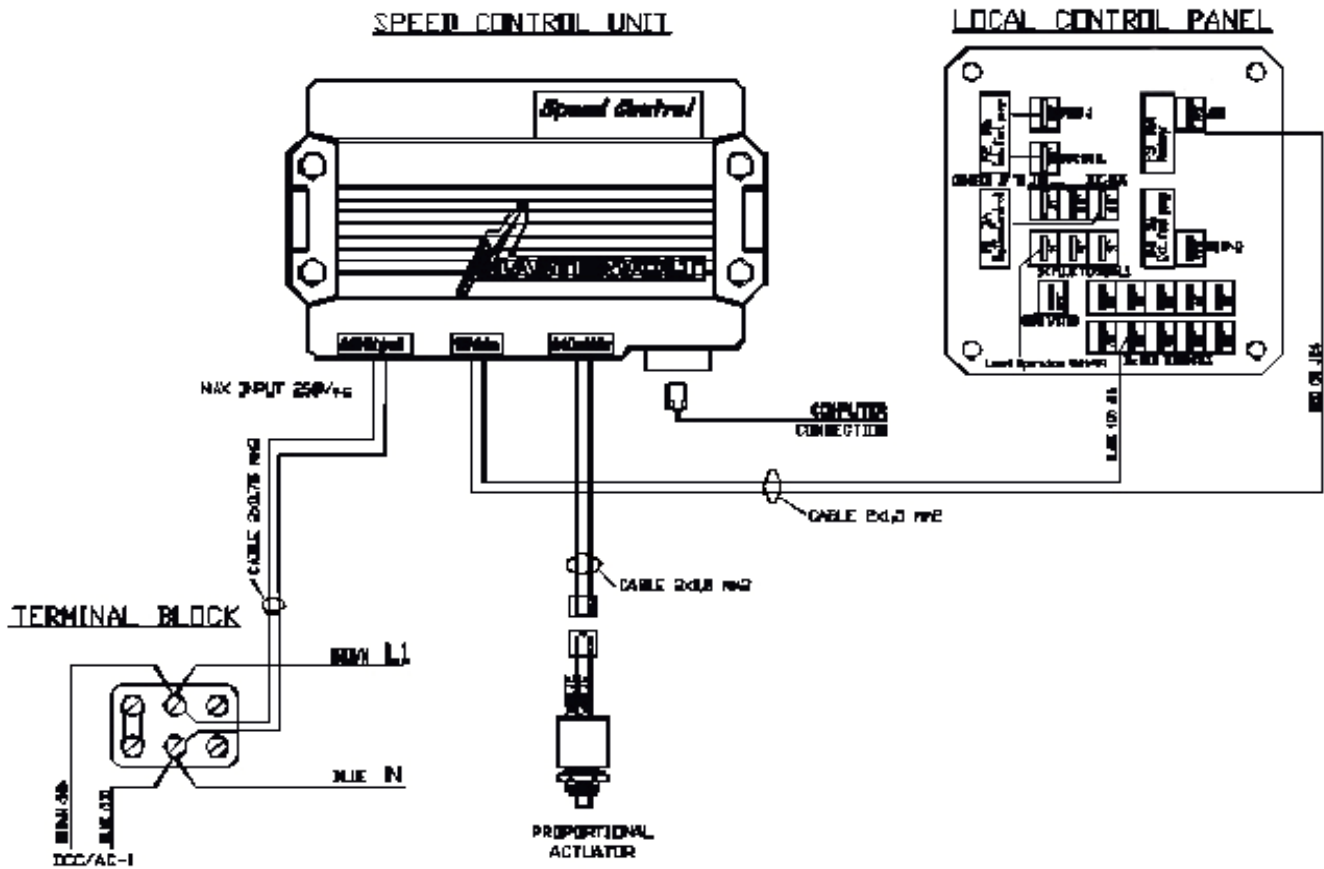

Fig. 42: Electronic governor.

In addition to the mechanical governor, the W-SQ6, 8 and 12 are standard equipped with an electronic governor. A governor keeps the speed (RPM=Rotations Per Minute) of the engine at a fixed value. The RPM of the engine correlates with the frequency of the electrical output (3000 RPM =50 Hz) of the alternator.

Under full load the RPM of the Whisper models that have only a mechanical governor can drop 75 RPM (=2.5 Hz) at full load and will go further down or collapse when further loaded. However the engines with the electronic governor will keep the RPM and frequency at the set value. As the voltage is related to the frequency, the voltage will be more stable as well.

The RPM represents power and the alternator performs better as well on a higher speed. Whisper models with an electronic governor will bring more power.

So the electronic governor offers three advantages: a more stable frequency and voltage and more power.

The electronic governor system contains two parts:

- 1 The actuator controls the engine speed. This actuator replaces the standard hold solenoid that is on all other mechanical controlled Whisper engines. The actuator controls the RPM directly on the fuel rack inside the fuel pump without levers and other mechanical transmissions.
- 2 A microprocessor keeps the speed at the set value by controlling the actuator. The microprocessor is programmed at the Whisper Power factory and many parameters are set to perform well. It should not be necessary to make adjustments. When adjustments are necessary this can only be done with the help of an interface to a computer and special software to get access to the microprocessor.

The Whisper Power electronic governor does not need a pickup device in the flywheel housing that counts the passing tooth of the flywheel and determines the exact RPM of the engine, because the processor uses the 50 Hz of the AC output voltage as a reference.

**4.11 REMOTE CONTROL PANEL DRAWINGS**

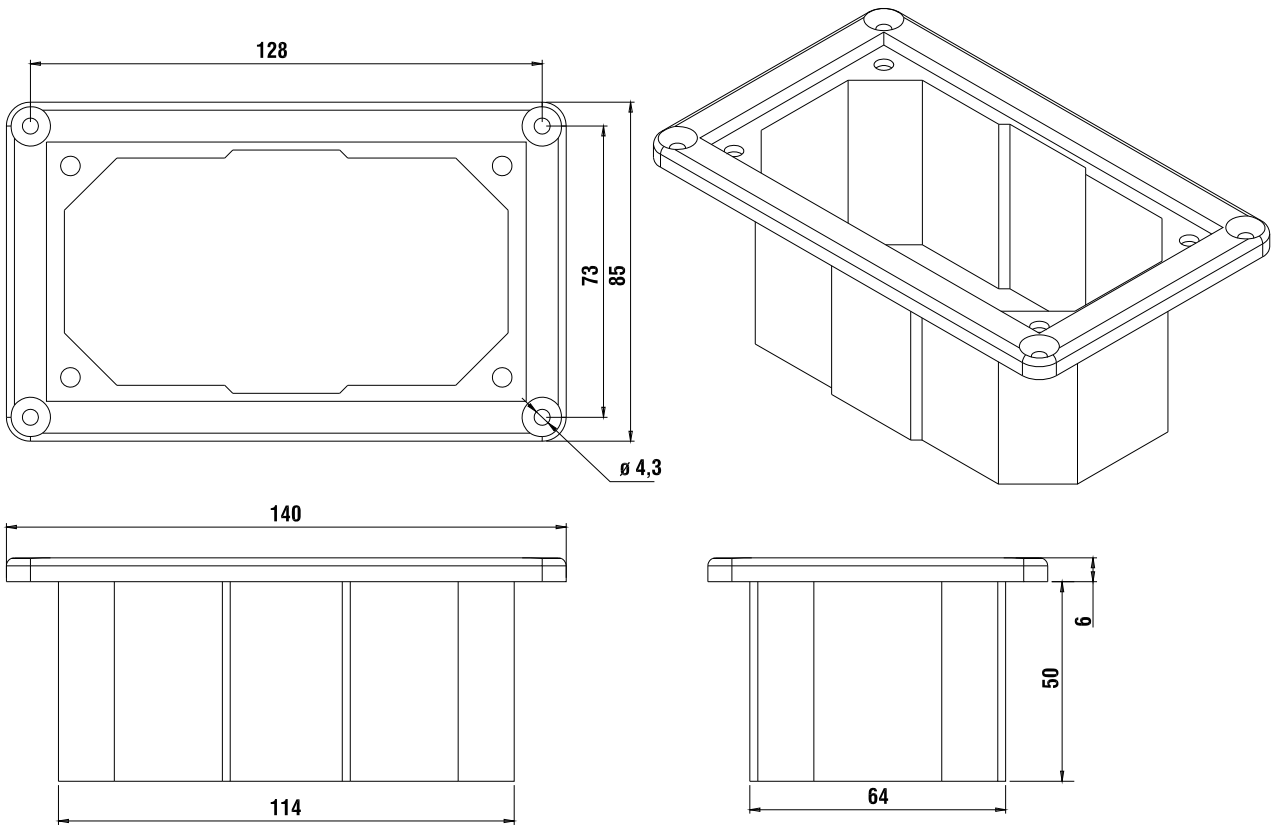

*Fig. 43: Whisper remote panel*

The remote panel comes in a carton that can be used as a template to drill the mounting hole

### 4.12 DIMENSIONS W-SQ6

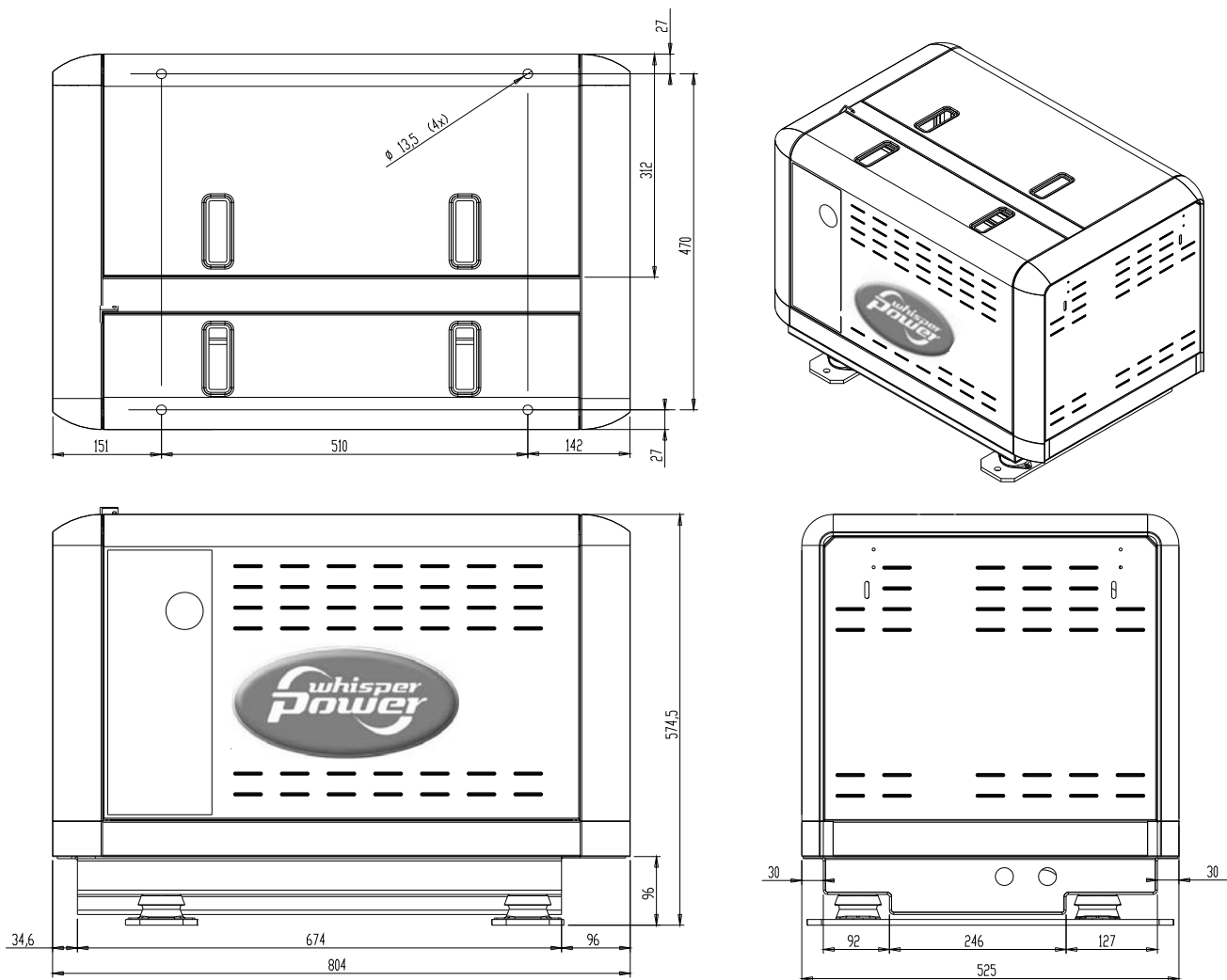

Fig. 44: Outer dimensions (mm) W-SQ6

#### CONNECTIONS W-SQ6:

- exhaust: 1 1/2"
- fuel hose: 5/16" (8 mm)
- radiator alternator: 3/4" (19 mm)
- radiator engine: 1" (25.4 mm)
- battery +: AWG 2 (25 mm<sup>2</sup>)
- battery -: AWG 2 (25 mm<sup>2</sup>)

#### BOX DIMENSIONS W-SQ6:

- length 80.5 cm (31.7')
- width 52.5 cm (20.7')
- height 58.0 cm (22.8')
- weight 240 kg (530 Lbs)

#### POWERCABLES ISO 13297 annex A

- 3 x AWG 12 (4 mm<sup>2</sup>) (not included)

#### REMOTE CONTROL:

- 15 meter (45 ft) 8 wire communication cable (included)

**4.13 DIMENSIONS W-SQ8**

Fig. 45: Outer dimensions (mm) W-SQ8

**CONNECTIONS W-SQ8:**

- exhaust: 1 ½"
- fuel hose: 5/16" (8 mm)
- radiator alternator: 3/4" (19 mm)
- radiator engine: 1¼" (32 mm)
- battery +: AWG 2 (25 mm<sup>2</sup>)
- battery -: AWG 2 (25 mm<sup>2</sup>)

**BOX DIMENSIONS W-SQ8:**

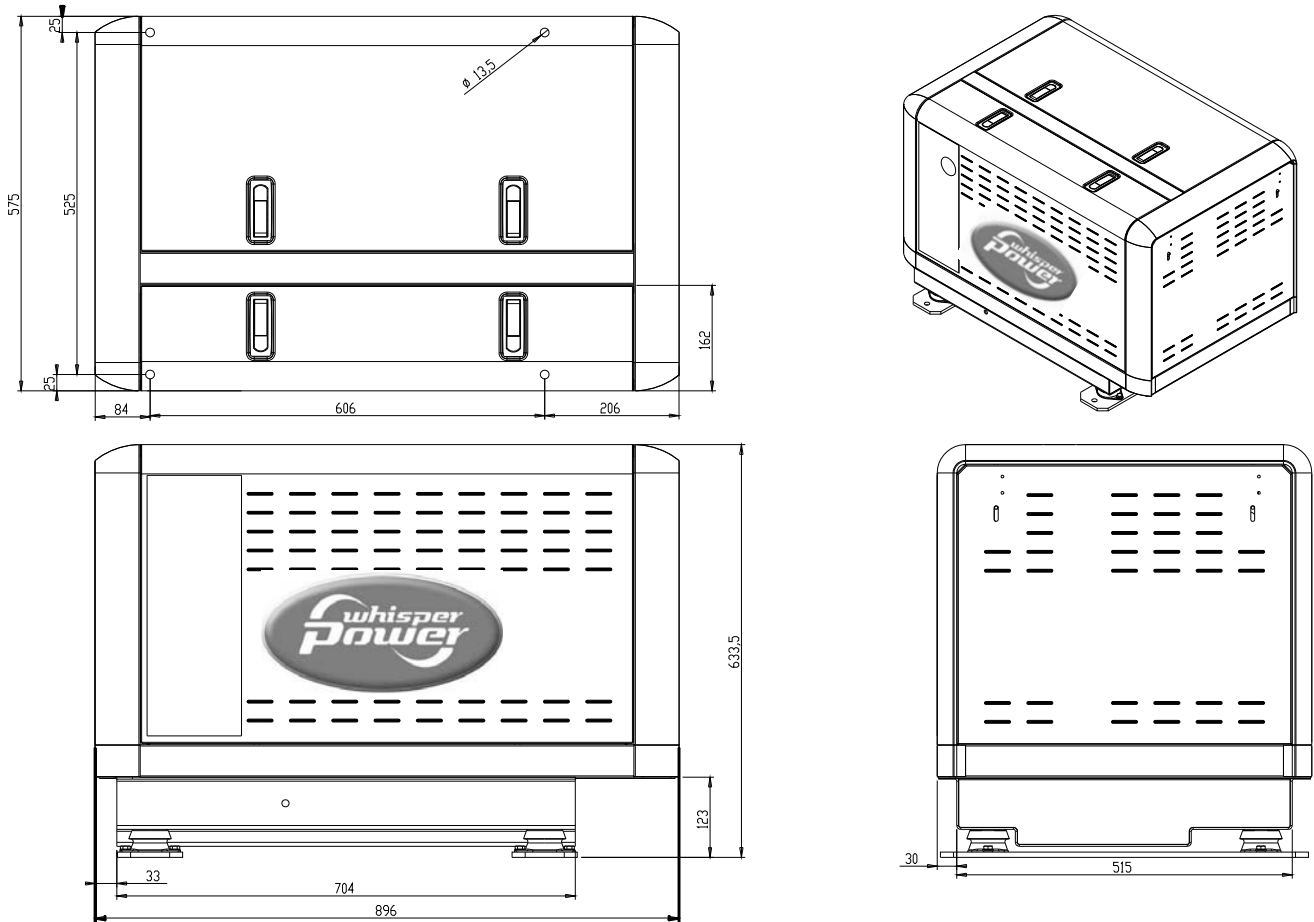
- length 900 mm (35.4")
- width 575 mm (22.6")
- height 640 mm (25.2")
- weight 335 kg

**POWERCABLES ISO 13297 annex A (not included)**

- 3x6 mm<sup>2</sup> (not included)

**REMOTE CONTROL:**

- 15 meter 8 wire communication cable (included)

#### 4.14 DIMENSIONS W-SQ12

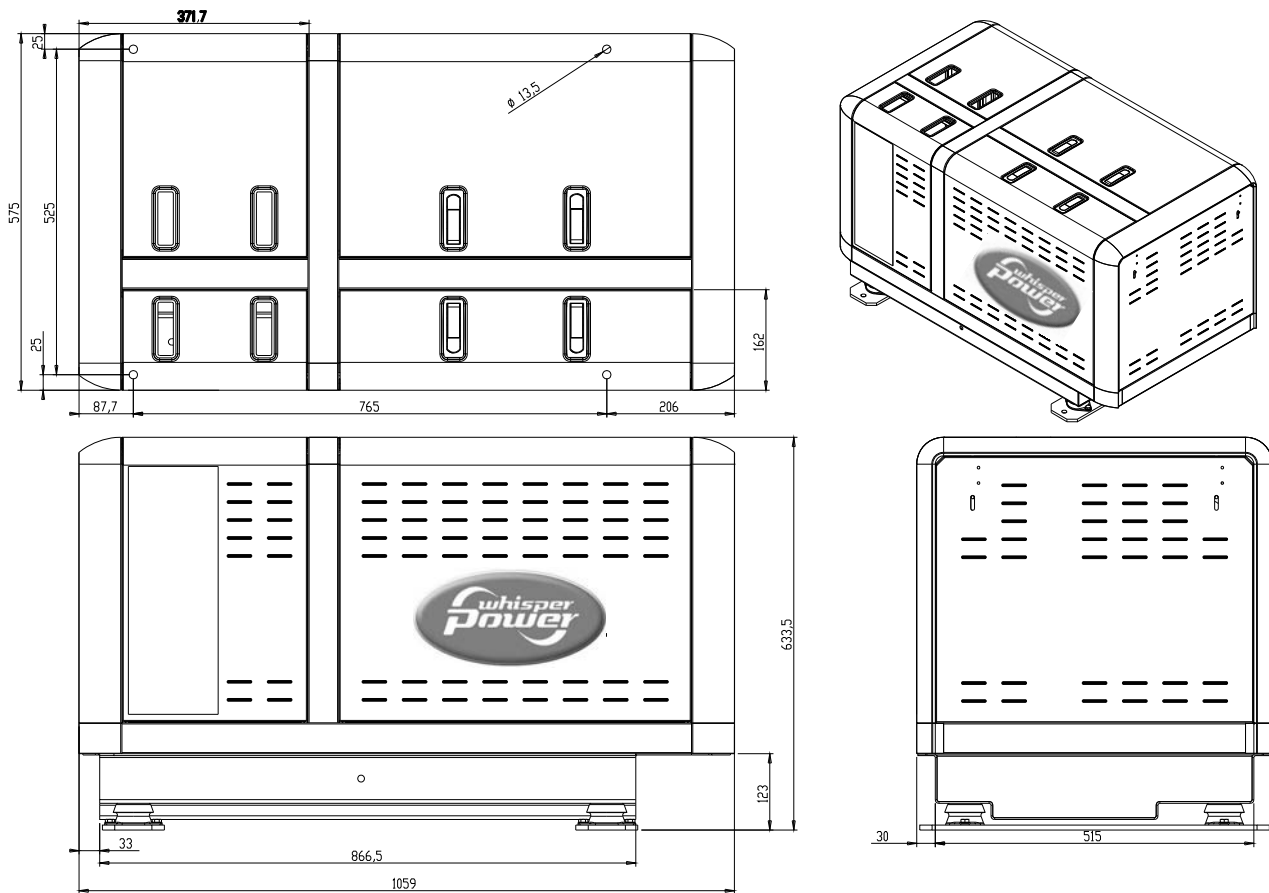

Fig. 46: Outer dimensions (mm) W-SQ12

#### CONNECTIONS W-SQ12:

- exhaust: 1 1/2"
- fuel hose: 5/16" (8 mm)
- radiator alternator: 3/4" (19 mm)
- radiator engine: 1 1/4" (32 mm)
- battery +: AWG 2 (25 mm<sup>2</sup>)
- battery -: AWG 2 (25 mm<sup>2</sup>)

#### BOX DIMENSIONS W-SQ12:

- length 1060 mm (41.7")
- width 575 mm (22.6")
- height 640 mm (25.2")
- weight 380 kg

#### POWERCABLES ISO 13297 annex A

- 3x10 mm<sup>2</sup> (not included)

#### REMOTE CONTROL:

- 15 meter 8 wire communication cable (included)

**4.15 DIMENSIONS W-SQ16**

Fig. 47: Outer dimensions (mm) W-SQ16

**CONNECTIONS W-SQ16:**

- exhaust: 1 1/2"
- fuel hose: 5/16" (8 mm)
- radiator alternator: 3/4" (19 mm)
- radiator engine: 1 1/4" (32 mm)
- battery +: 35 mm<sup>2</sup>
- battery -: 35 mm<sup>2</sup>

**BOX DIMENSIONS W-SQ16:**

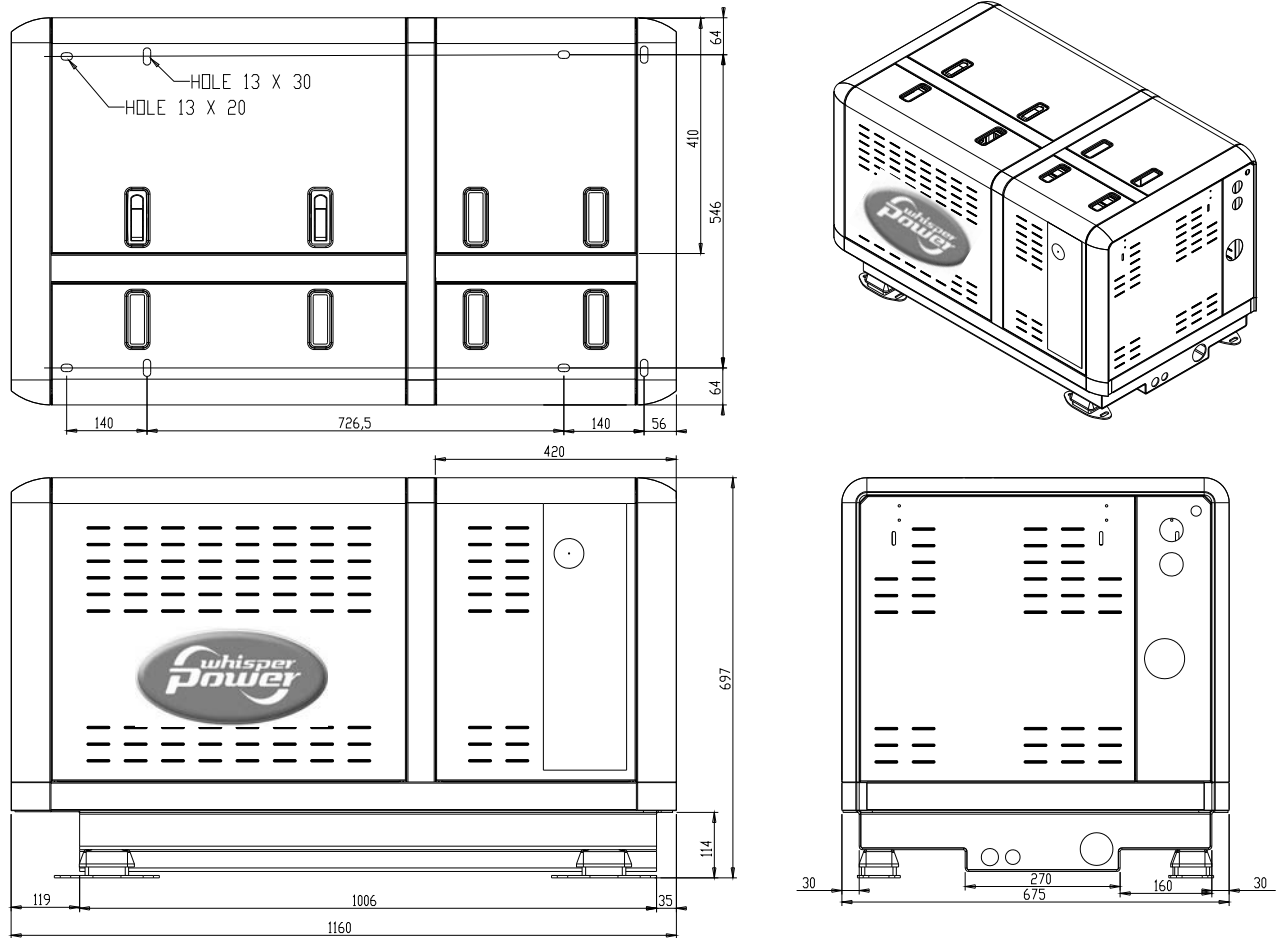
- length 1160 mm (45.7")
- width 680 mm (26.8")
- height 700 mm (27.6")
- weight 454 kg

**POWERCABLES ISO 13297 annex A**

- 3x16 mm<sup>2</sup> (not included)

**REMOTE CONTROL:**

- 15 meter 8 wire communication cable (included)

A template to drill the mounting holes of the W-SQ16 is included in the delivery.



Kelvinlaan 82, 9207 JB Drachten, Nederland  
Tel : + 31-512-571550 / Fax : + 31-512-571599  
[www.whisperpower.eu](http://www.whisperpower.eu) / [info@whisperpower.nl](mailto:info@whisperpower.nl)