

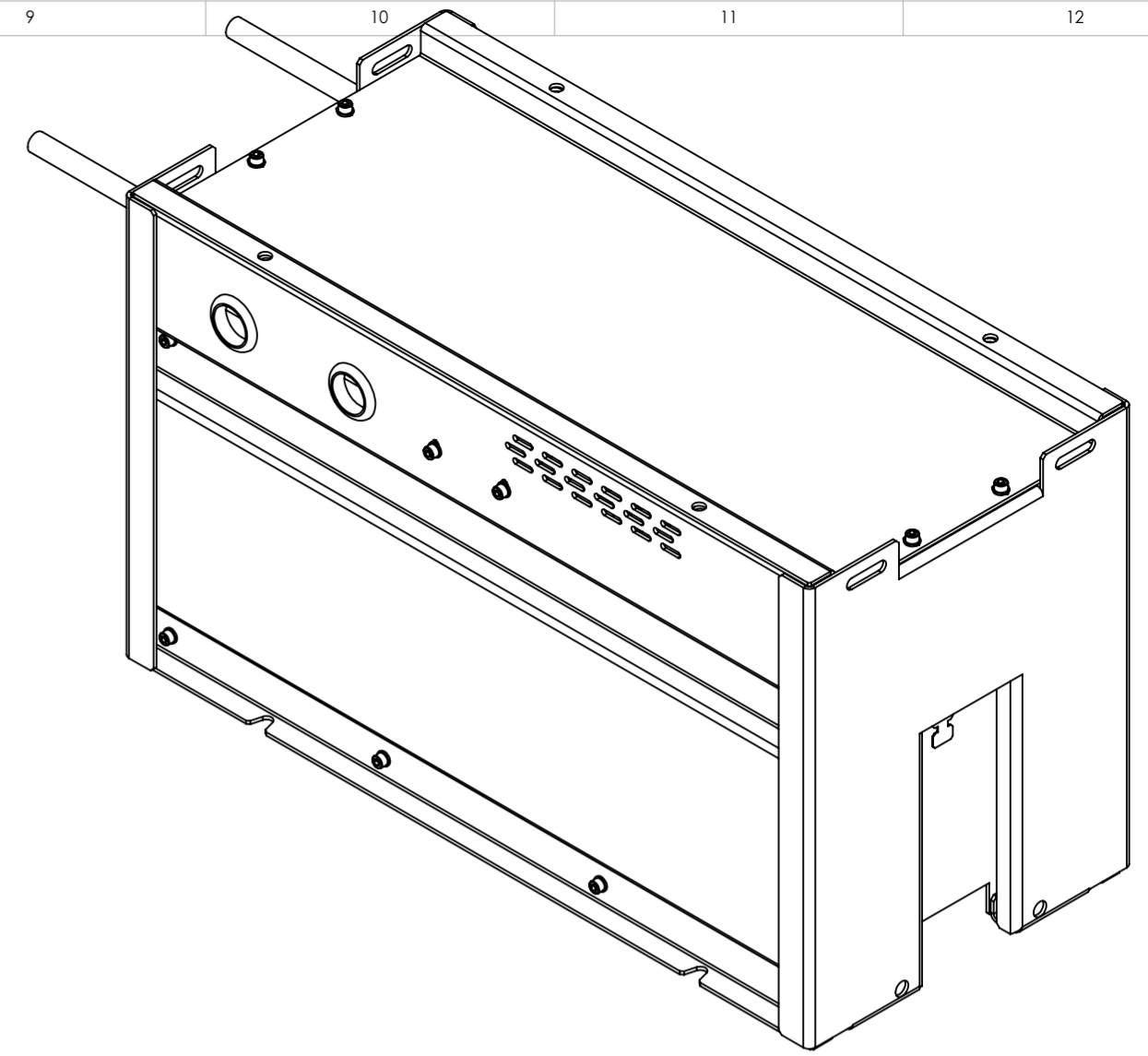

22	16	plain washer 7349 heavy_din	plain washer 7349 heavy_din	50211421
21	1	Battery Cable 70 mm² - 1.5 m black	6014A12018	NOT_REQUIRED
20	1	Battery Cable 70 mm² - 1.5 m red	6014A12022	NOT_REQUIRED
19	6	Hi Power Cells Busbar	6014P131159	NOT_REQUIRED
18	14	Washer M14 ISO 7089	Washer M14 ISO 7089	50211420
17	8	Spring lock washer DIN 6905 - 11	M14 Springwasher	50211458
16	14	ISO 4014 - M14 x 20-N	ISO 4014 - M14 x 20-N	50211719
15	16	Hexagon socket head cap screw ISO 4762 - M3 x 10	socket head cap screw 4762_din	50211239
14	16		spring lock washer 2_din	NOT_REQUIRED
13	32	Binnenzesk bout A2 M6 x 25	50211206 Binnenzesk bout A2 M6 x 25	50211206
12	32	ONDERLEGRING VZ M6	50211404 ONDERLEGRING VZ M6	50211404
11	8	Li-ion cells Busbar 400 Ah / 700 Ah	6014P121060	NOT_REQUIRED
10	1	700 Ah-Backside panel	6014P121048	40290169
9	6	Doorvoertule 38 x 32 x 2	50209042 Doorvoertule 38 x 32 x 2	50209042
8	1	Top Cover	6014P121042	40290172
7	1	Endcover Assy-Left Version	6014A121052	40290178
6	1	Endcover Assy-Right Version	6014A121054	40290188
5	1	700 Ah-Frontside panel	6014P121043	40290173
4	1	PCB + Support Assy	6014A121051	NOT_REQUIRED
3	2	Hi Power Cells Endpanel- assy	6014A121053	NOT_REQUIRED
2	4	Thundersky Battery 700 Ah	Accu-cel 700 Ah	40290055
1	1	Hi Power Cells Accubak-Bottom-Assy-700 AHA	6014A121057	40290170
ITEM NO.	QTY.	DESCRIPTION	DRAWING	ARTICLE No.
UNLESS OTHERWISE SPECIFIED:		TOLERANCE PRINCIPLE ISO 8015	FINISH:	DO NOT SCALE DRAWING
CHAMFER SHARP EDGES		PROJECTION : THIRD ANGLE	Material:	SHEET FORMAT:
GENERAL TOLERANCE NEN ISO 2768		UNITS : mm		A2
FORM AND PLACE TOLERANCES NEN-ISO 1101				TITLE:
WELDING SYMBOL NEN EN 22553				Hi Power Cells Accu cabinet 700 Ah
ROUGHNESS ACC. to NEN3634				ARTICLE NO. 40290175
NAME	SIGNATURE	DATE	STATUS:	REVISION
M.B.		19-10-2012	Design Review	
CHKD	J.R.	24-12-2012	DRAWING:	
			6014A121058	
PRINTED		23-1-2014	Weight: gram	SCALE:1:5 SHEET 1 OF 2

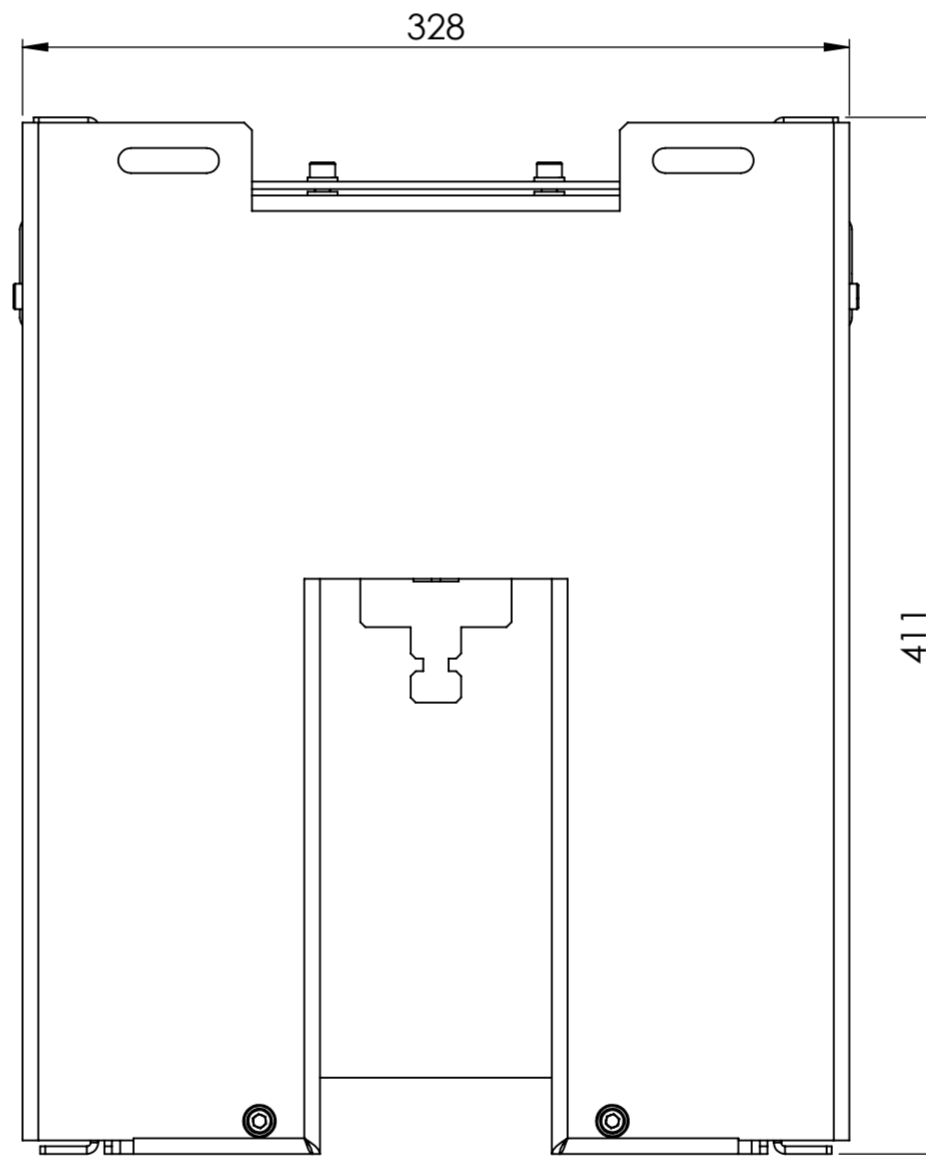

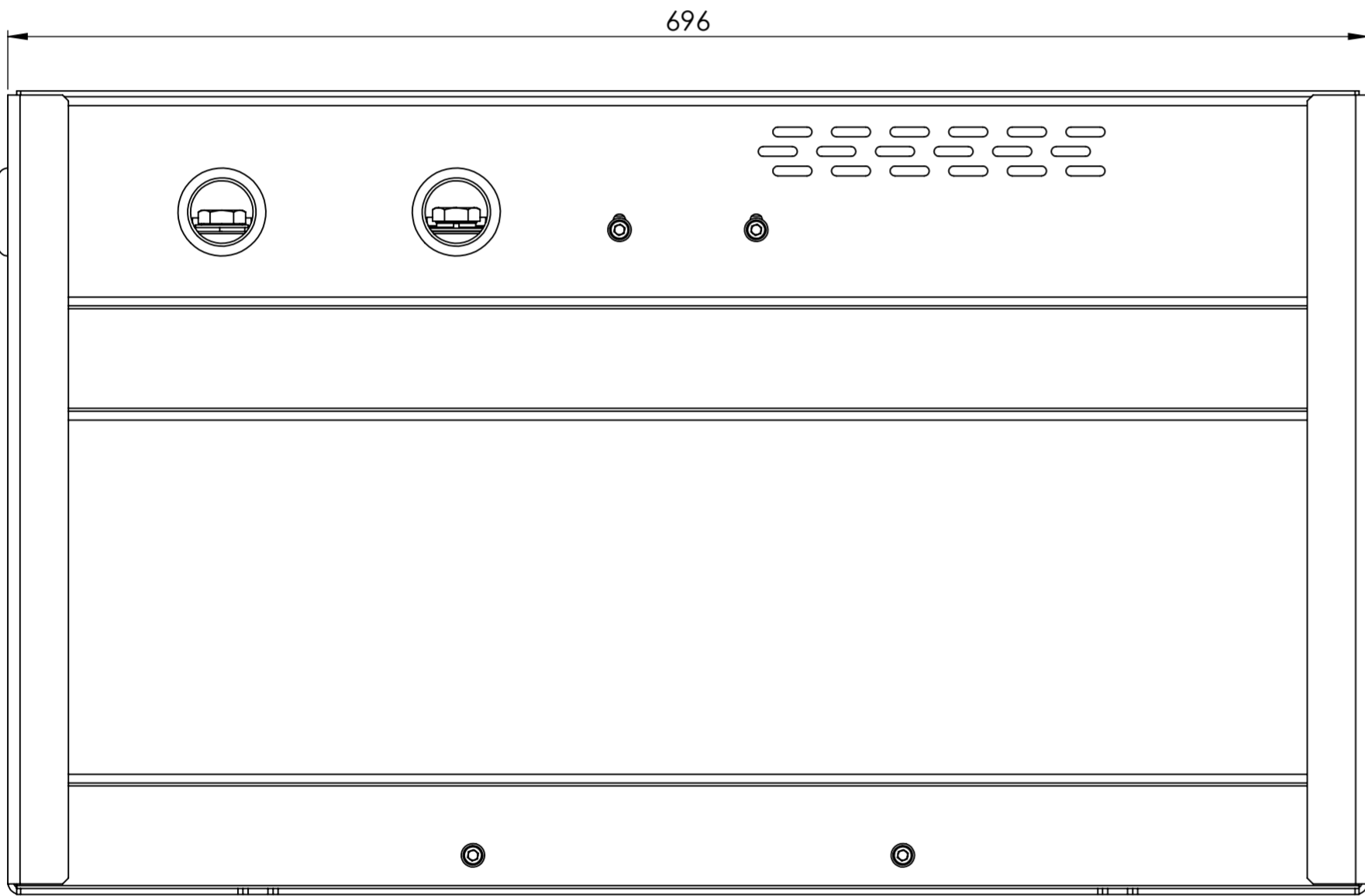
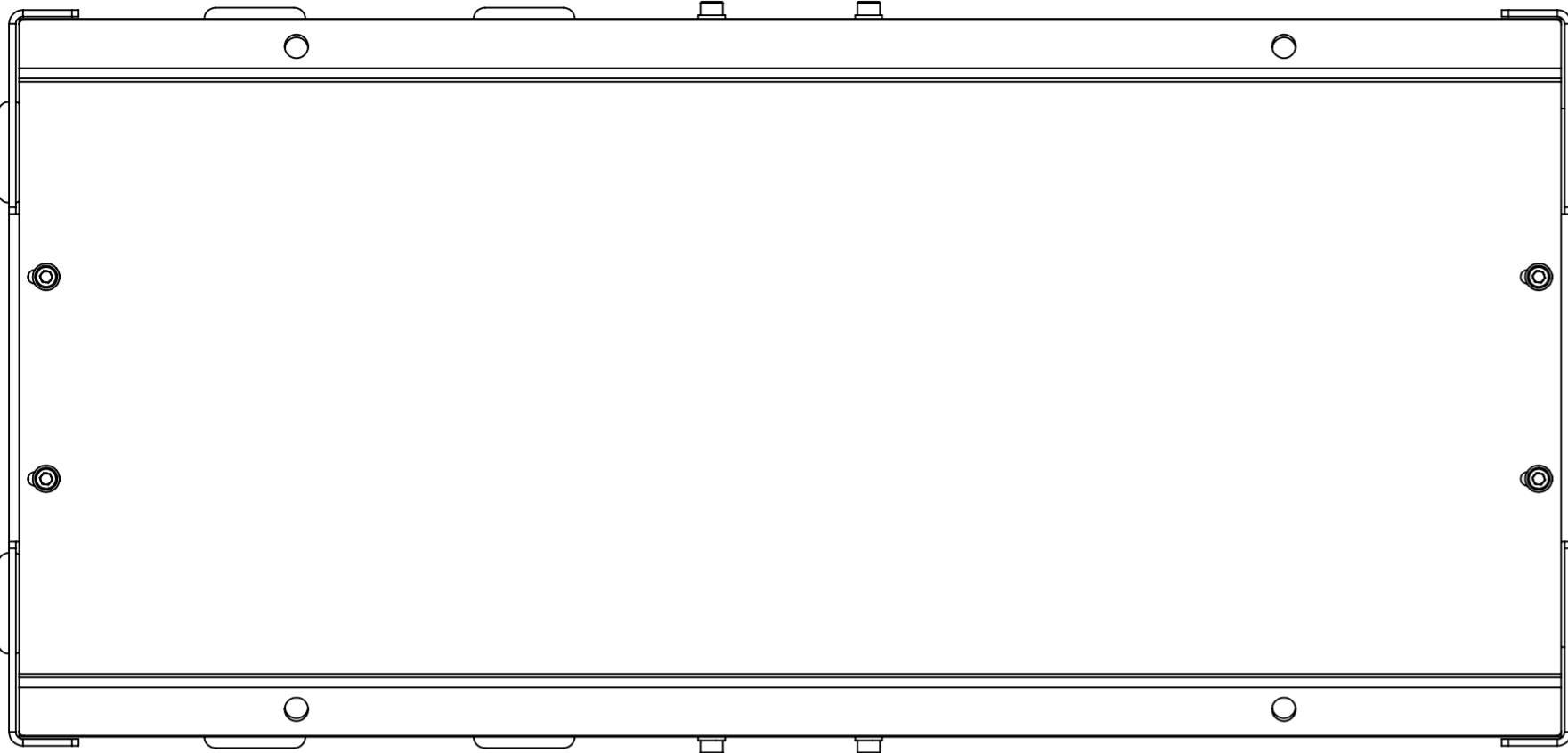
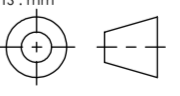

UNLESS OTHERWISE SPECIFIED: CHAMFER SHARP EDGES GENERAL TOLERANCE NEN ISO 2768 FORM AND PLACE TOLERANCES NEN-ISO 1101 WELDING SYMBOL NEN EN 22553 ROUGHNESS ACC. to NEN3634		TOLERANCE PRINCIPLE ISO 8015		FINISH: Material:		DO NOT SCALE DRAWING		
PROJECTION : THIRD ANGLE UNITS : mm				SHEET FORMAT: A2		TITLE: HI Power Cells Accu cabinet 700 Ah		
DRAWN	M.B.	DATE	19-10-2012	STATUS: Design Review		ARTICLE NO. 40290175		REVISION
CHKD	J.R.	DATE	24-12-2012	DRAWING:		SCALE:1:3		
PRINTED		DATE	23-1-2014	6014A121058		SHEET 2 OF 2		
				Weight: gram				